

Comparison of Active and Passive Optical Access Networks

Claus Popp Larsen, Anders Gavler & Kun Wang

Acreo Netlab

claus.popp.larsen@acreo.se

Optical access network technologies



- Passive optical networks (**PON**, p2mp)
 - ▶ Dominating in Asia and the US
- Active optical networks (**AON**, p2p Ethernet, active Ethernet, etc)
 - ▶ Dominating in Europe (84% in Dec 2009, [IDATE for FTTH Council Europe](#))
- Today mostly tree structures (access rings in some AON deployments)
- WDM PON deployed in Korea – probably most as feeder networks to PONs and AONs

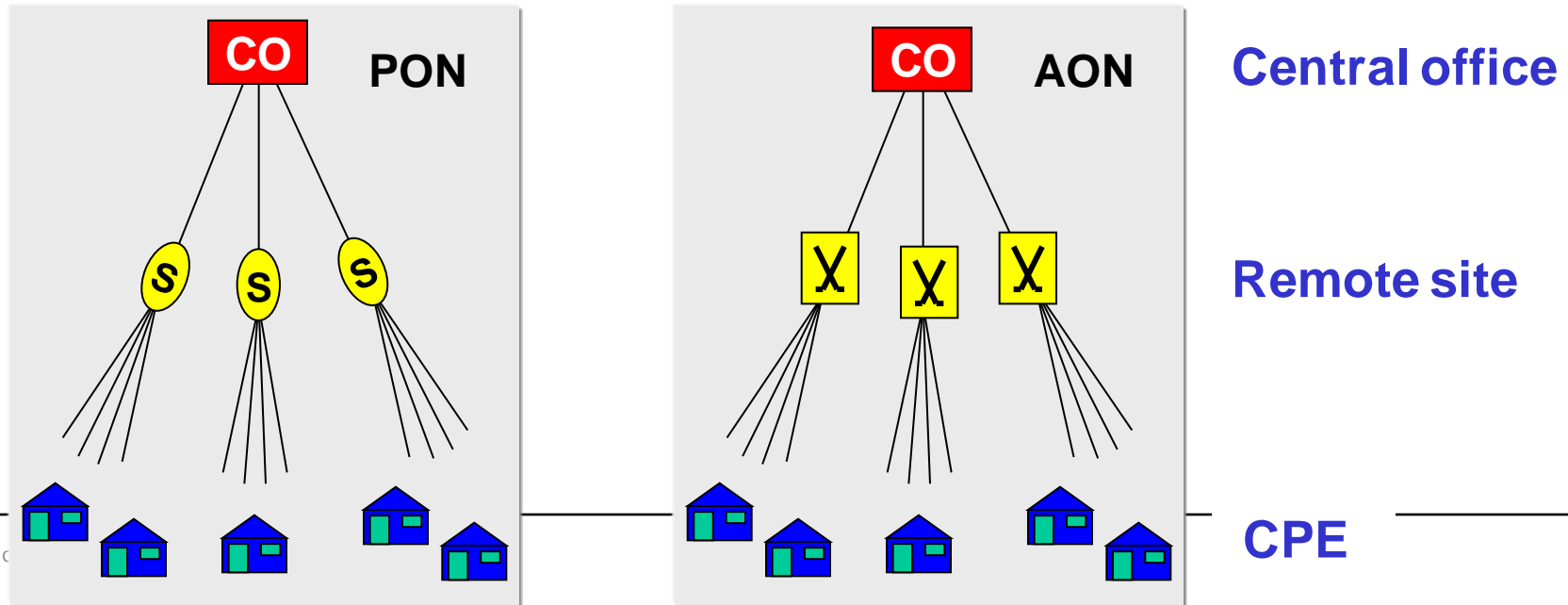

- Definition of *active* and *passive* optical networks
- Comparison of four different PON and AON architectures
- Reference model for analyzing and comparing different access technologies
- Examples of how to apply the reference model
- Summary

Active vs passive

Definitions of *active* and *passive* are inconsistent and confusing

Definition that preserves present perceptions of PON and AON:

“ Any system that includes nodes which main *function* is to forward steady state traffic, and that does not need active configuration to do so is called a **passive optical network**. A system that needs active configuration of such nodes in order to achieve the same result is called an **active optical network** “

- ▶ Optical switches for protection still possible in PON
- ▶ Amplification still possible for PON

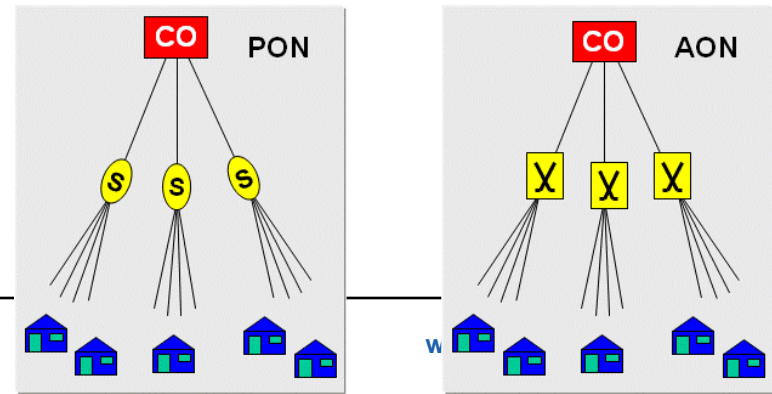

Scope of the present study



- It is *not* a detailed techno-economic study
- It presents a reference model that eases high-level analysis and comparison between different access technologies
- The reference model can be used as a framework for detailed techno-economic comparison
- The model can also be used for FTTx and non-optical access technologies as well as green studies

FTTx comparison

- Equipment, topology, architecture



CPE Remote site CO

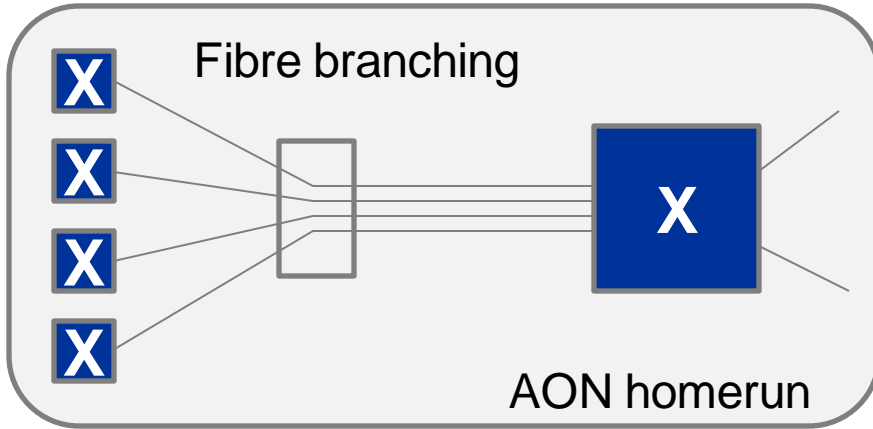

CPE Remote site CO

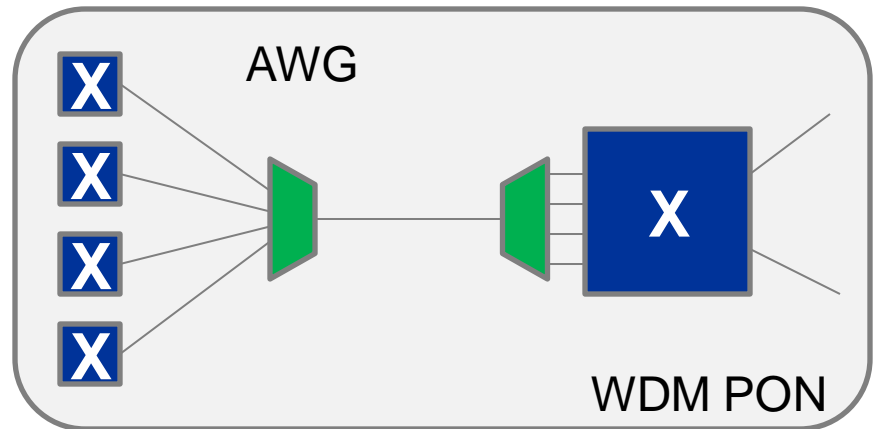
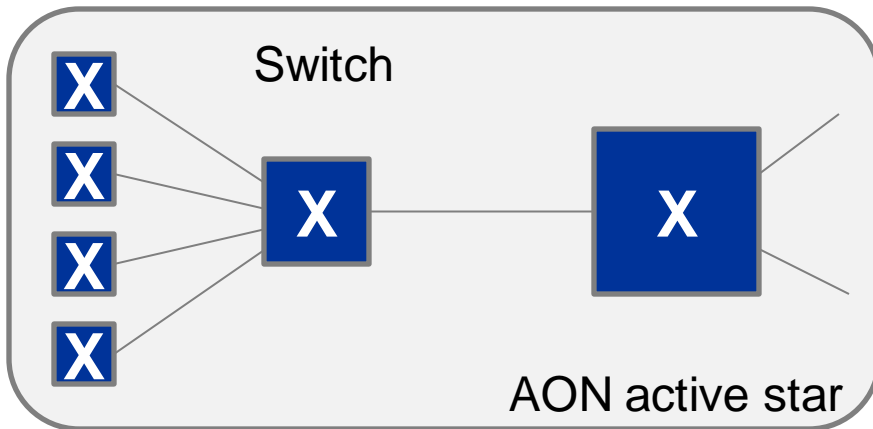
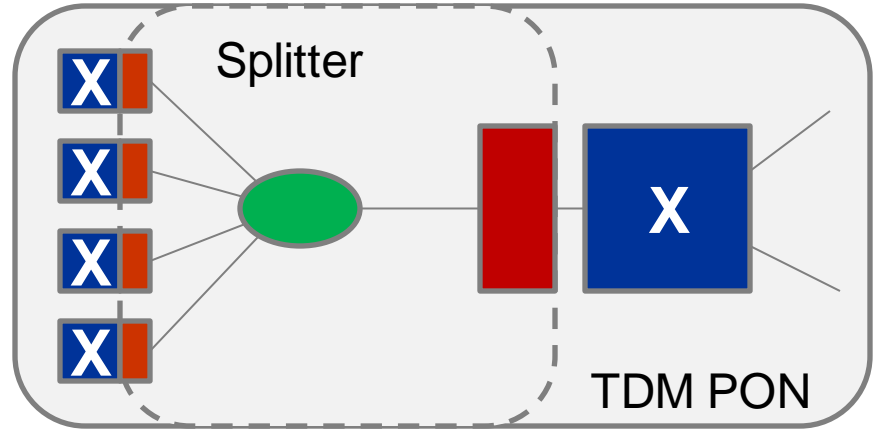

Ethernet equipment

TDM equipment

Optical equipment

Generic access reference model

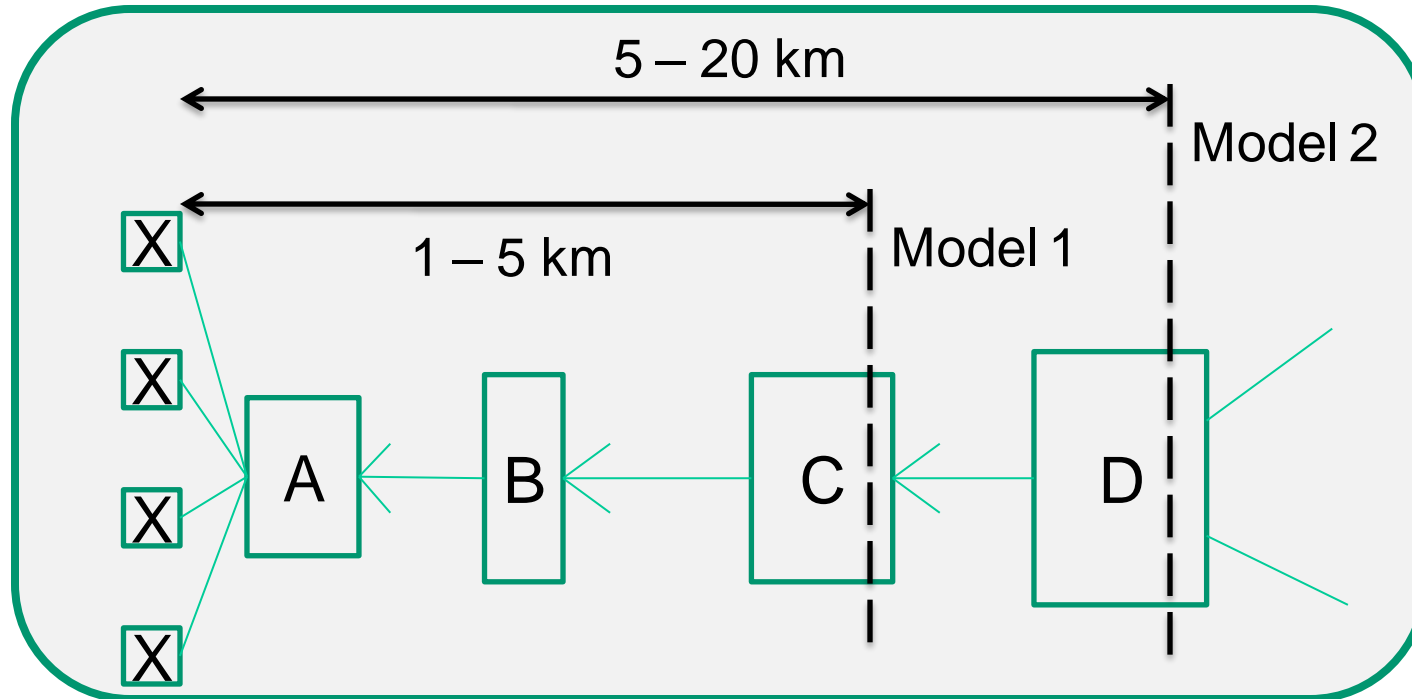

- PON splitter possible at A, B, C
- Switch possible at all sites or only one
- CO at C or D (or both for AON)
- Model 2 more probable for rural locations

Access network deployment



Inputs for techno-economic studies

Reference model + access topologies/architectures

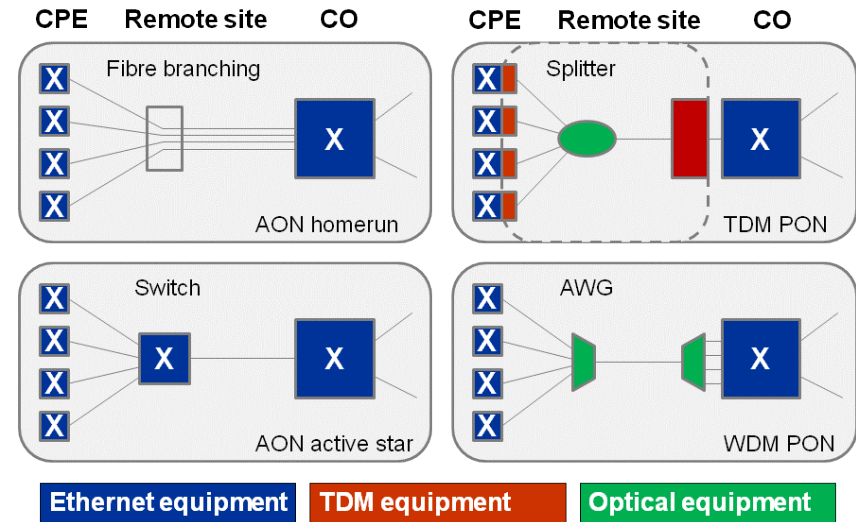
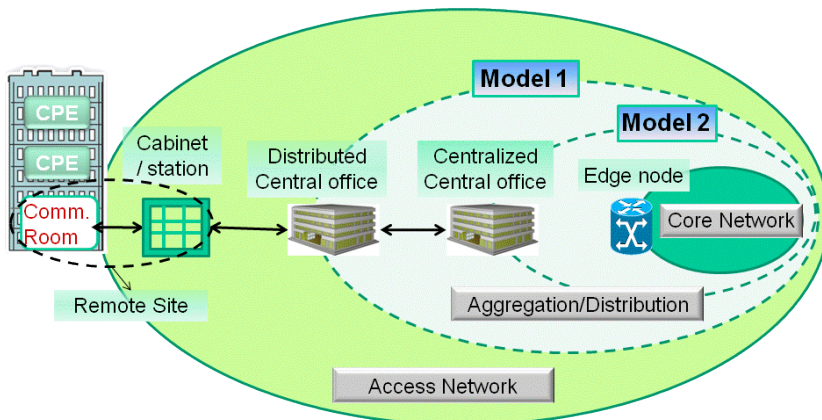

... can be used as base for detailed techno-economic model

	AON – active star	AON – home run	TDM PON	WDM PON
Transceivers between OLT and ONT	2+2N	2N	3+N	2N
Power budget	Lowest	As PON minus splitting losses	Highest due to splitting losses and longer distance	As home run plus 2x AWG losses
Trenching	Almost identical, but larger cable needed for the home run case (see below)			
Duct space	Cable containing one (or a few) fibre pair between all sites	Cable between OLT and remote site contains N fibre pairs	As active star	As active star
CPE CAPEX	Lowest	Lowest	Higher than AON due to additional TDM equipment plus need for higher line rate	Higher than AON due to either coloured optics or reflectors
Remote site CAPEX	E/O equipment: Switch Urban: Switch site with power available Rural: House/cabinet needs to be built and powered	E/O equipment: None Possibly cabinet or man hole needed where fibre pairs are divided	E/O equipment: Splitter Urban: Splitter site available Rural: Cabinet to be built	E/O equipment: AWG Urban: Splitter site available Rural: Cabinet to be built
Central office CAPEX	Switch with 2N interfaces towards costumers. Same size switch fabric for all four designs in the table.	Switch with 2N interfaces towards costumers.	Switch with 1 high speed interface towards costumers. TDM equipment in OLT.	Switch with 2N interfaces towards costumers. Coloured optics and (based on design) additional optics related to broadband source.
OPEX at remote site	Power at switch cabinet	none	none	none
Upgrade to 10x higher bit rates	100M/1G TRx at customer site exist, but access switch needs replacement	End-to-end fibre transparent	End-to-end fibre transparent, but replacement of OLT + ONT	End-to-end fibre transparent
Interoperability	High – everything is Ethernet	High – everything is Ethernet	Limited	Limited

	AON – active star	AON – home run	TDM PON	WDM PON
Transceivers between OLT and ONT	2+2N	2N	3+N	2N
Power budget	Lowest	As PON minus splitting losses	Highest due to splitting losses and longer distance	As home run plus 2x AWG losses
Trenching	Almost identical, but larger cable needed for the home run case (see below)			
Duct space	Cable containing one (or a few) fibre pair between all sites	Cable between OLT and remote site contains N fibre pairs	As active star	As active star
CPE CAPEX	Lowest	Lowest	Higher than AON due to additional TDM equipment plus need for higher line rate	Higher than AON due to either coloured optics or reflectors
Remote site CAPEX	E/O equipment: Switch Urban: Switch site with power available Rural: House/cabinet needs to be built and powered	E/O equipment: None Possibly cabinet or man hole needed where fibre pairs are divided	E/O equipment: Splitter Urban: Splitter site available Rural: Cabinet to be built	E/O equipment: AWG Urban: Splitter site available Rural: Cabinet to be built
Central office CAPEX	Switch with 2N interfaces towards costumers. Same size switch fabric for all four designs in the table.	Switch with 2N interfaces towards costumers.	Switch with 1 high speed interface towards costumers. TDM equipment in OLT.	Switch with 2N interfaces towards costumers. Coloured optics and (based on design) additional optics related to broadband source.
OPEX at remote site	Power at switch cabinet	none	none	none
Upgrade to 10x higher bit rates	100M/1G TRx at customer site exist, but access switch needs replacement	End-to-end fibre transparent	End-to-end fibre transparent, but replacement of OLT + ONT	End-to-end fibre transparent
Interoperability	High – everything is Ethernet	High – everything is Ethernet	Limited	Limited

FTTx comparison

- Equipment, topology, architecture



CPE Remote site CO

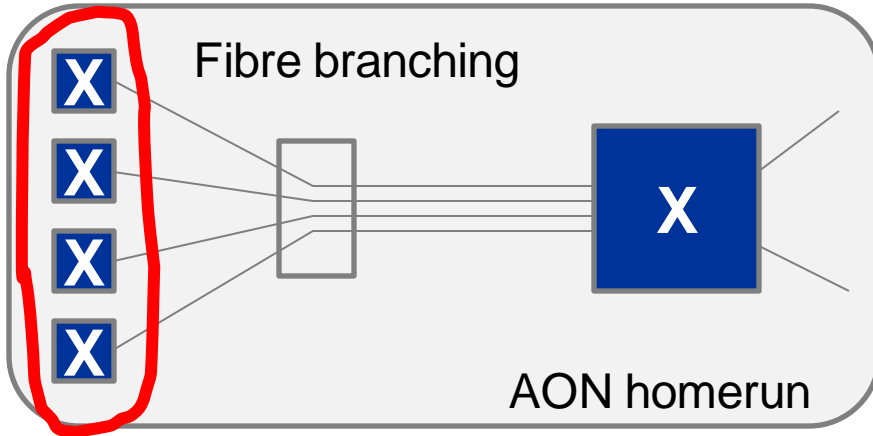

CPE Remote site CO

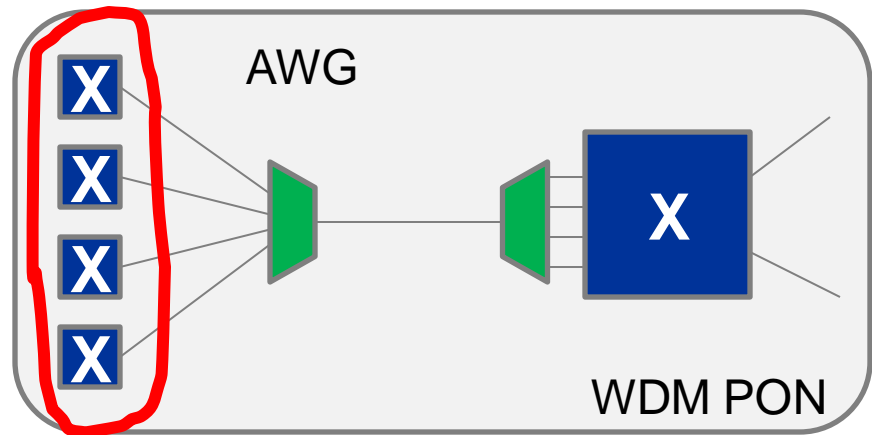
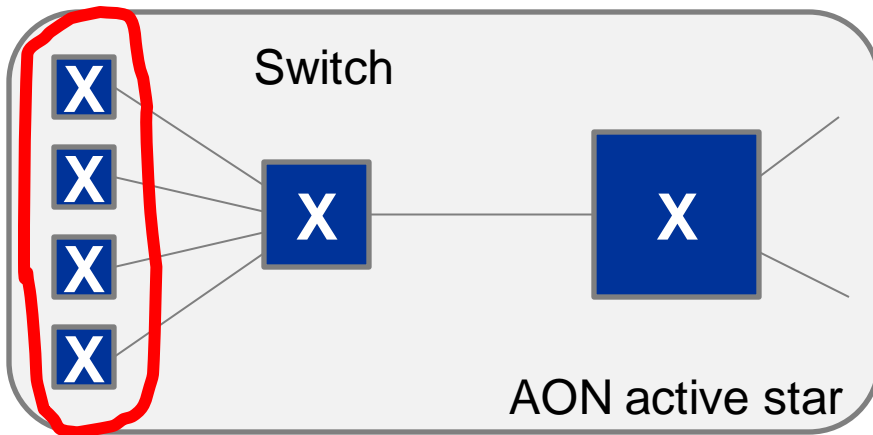
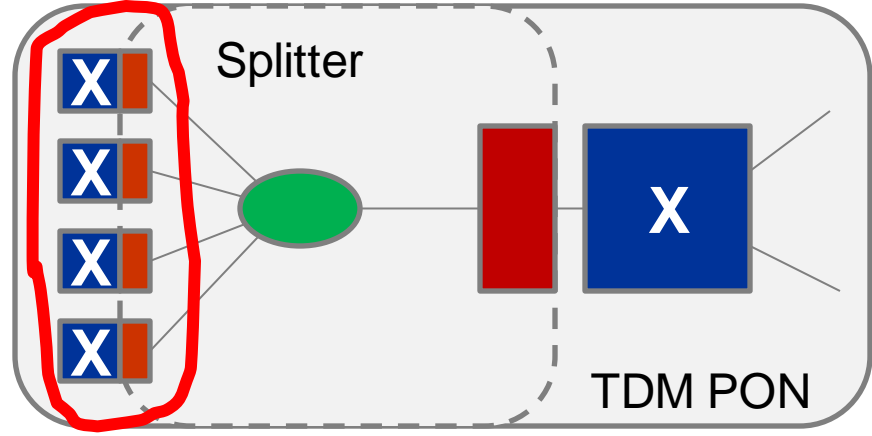

Ethernet equipment

TDM equipment

Optical equipment

	AON – active star	AON – home run	TDM PON	WDM PON
Transceivers between OLT and ONT	2+2N	2N	3+N	2N
Power budget	Lowest	As PON minus splitting losses	Highest due to splitting losses and longer distance	As home run plus 2x AWG losses
Trenching	Almost identical, but larger cable needed for the home run case (see below)			
Duct space	Cable containing one (or a few) fibre pair between all sites	Cable between OLT and remote site contains N fibre pairs	As active star	As active star
CPE CAPEX	Lowest	Lowest	Higher than AON due to additional TDM equipment plus need for higher line rate	Higher than AON due to either coloured optics or reflectors
Remote site CAPEX	E/O equipment: Switch Urban: Switch site with power available Rural: House/cabinet needs to be built and powered	E/O equipment: None Possibly cabinet or man hole needed where fibre pairs are divided	E/O equipment: Splitter Urban: Splitter site available Rural: Cabinet to be built	E/O equipment: AWG Urban: Splitter site available Rural: Cabinet to be built
Central office CAPEX	Switch with 2N interfaces towards costumers. Same size switch fabric for all four designs in the table.	Switch with 2N interfaces towards costumers.	Switch with 1 high speed interface towards costumers. TDM equipment in OLT.	Switch with 2N interfaces towards costumers. Coloured optics and (based on design) additional optics related to broadband source.
OPEX at remote site	Power at switch cabinet	none	none	none
Upgrade to 10x higher bit rates	100M/1G TRx at customer site exist, but access switch needs replacement	End-to-end fibre transparent	End-to-end fibre transparent, but replacement of OLT + ONT	End-to-end fibre transparent
Interoperability	High – everything is Ethernet	High – everything is Ethernet	Limited	Limited

FTTx comparison

- Equipment, topology, architecture



CPE Remote site CO

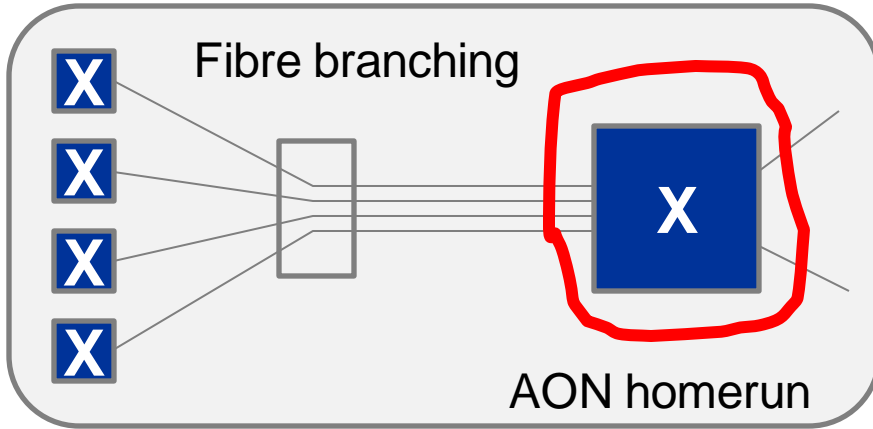

CPE Remote site CO

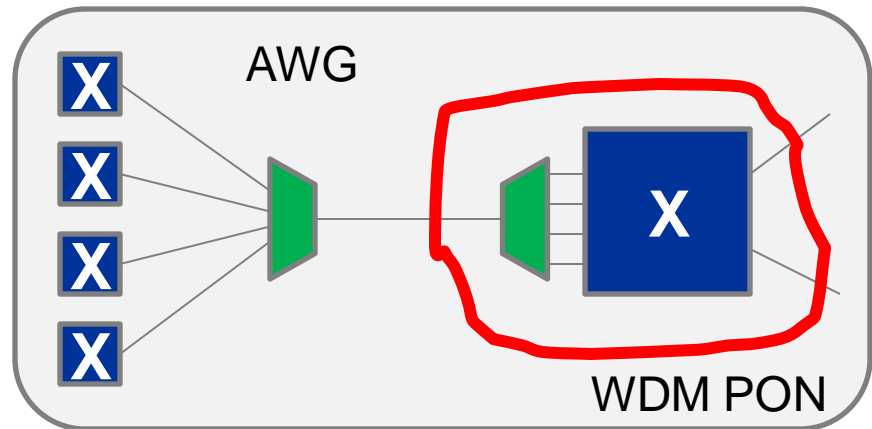
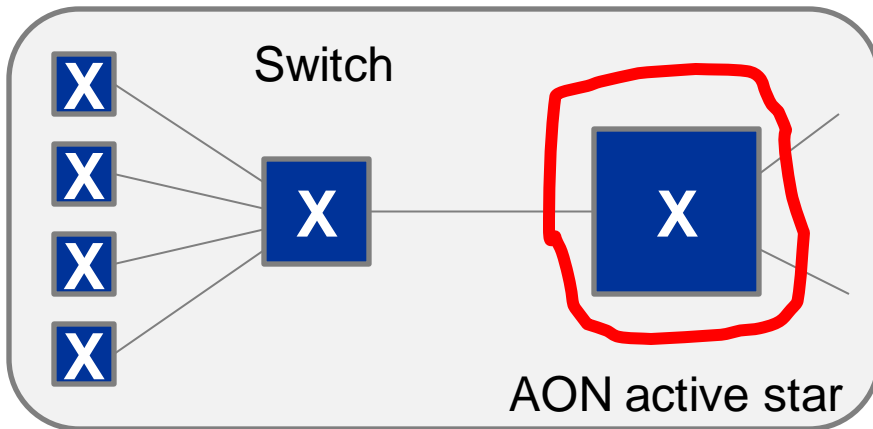
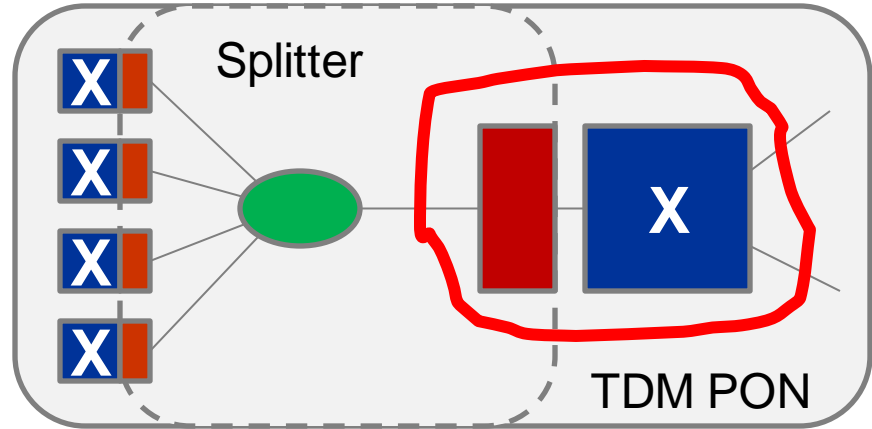

Ethernet equipment

TDM equipment

Optical equipment

Summary



- Definition of the terms *active* and *passive* for PON and AON based on functionality rather than technology
- Comparative model enables high-level comparison between optical access network technologies
- Can be used as a base for techno-economic studies – includes relevant parameters in a fair way

Observe,

- The model can clarify business models (e.g., unbundling related) – but these can "overrule" a techno-economic study
- Political decisions, historical concerns, time frame of investment, etc, will also affect choice of technology
- Prime cost: Digging and trenching
- Prime issue: Fibre to each household



Thank you !!!

Contact: claus.popp.larsen@acreo.se