

European and American Research Toward Next-Generation Optical Access Networks

Leonid G. Kazovsky¹, Claus Popp Larsen², Dirk Breuer³, Anders Gavler², Mikhail Popov², Kun Wang², Gunnar Jacobsen², Erik Weis³, Christoph Lange³, ShingWa Wong¹, She-Hwa Yen¹, Vinesh Gudla¹, Pegah Afshar¹

¹ Stanford University, USA; ² Acreo AB, Sweden; ³ Deutsche Telekom

ABSTRACT

Next-generation optical access networks will deliver substantial benefits to consumers including a dedicated high-QoS access to bit rates of hundreds of Megabits per second. They must also deliver significant benefits to network owners/operators to justify the needed infrastructure investment expected to reach billions of Euros. Benefits to network owners/operators are expected to include reduced total cost of ownership, due to higher reliability, lower energy consumption, better flexibility and efficiency, and a smaller number of sites needed to support network operations. This paper will describe recent progress toward that goal including R&D efforts in Europe under the FP7 projects ALPHA and OASE and in the US at Stanford University under the SUCCESS and DAN projects.

1. INTRODUCTION

With ever-increasing demand for bandwidth, optical access networks such as Passive Optical Networks (PONs) and active optical networks (AON) are being deployed by many service providers worldwide. Current PONs can support rates of 2.5 Gbps and a reach of 20 km and AONs can support up to 1 Gbit/s per subscriber symmetrical connections. While this is sufficient to meet the near-term user-bandwidth requirements, higher rates and newer technologies such as WDM are required for next generation PONs to support future demands. The ideal scenario would be to have the increased bandwidth at similar or lower cost compared to present-day networks. One technology that could provide a solution keeping in mind the demands on future networks is the Active Optical Network (AON)-based architecture. With the in-built redundancy of Ethernet, AONs have in particular the advantage of keeping networks localized and can reduce the load on backbone servers. Another important factor in migration to newer architectures is to bring down the total operating costs (OpEx) of the network and the OASE (Optical Access Seamless Evolution) project is a step in this direction which envisages Central Office (CO) consolidation that could bring down the Total Cost of Ownership (TCO) of the network. Reducing the OpEx would also allow the operator greater freedom to provide more services to the customer. The challenge is to integrate these technologies in already-deployed infrastructures and to fulfil the upgrades in an incremental and non-interruptive manner, i.e. graceful evolution over the next several years. Increasing integration of wireless technologies and the use of novel components are important to continue offering flexible and cost effective broadband access. One of the key PON challenges is to design and introduce low-cost reconfigurable devices that also preserve the passive nature of PON. With the rapid development within optical access networking it is impossible to foresee exactly what "next generation" will bring us, which is exemplified in this paper. The business model can dictate the preferred technology, and today the extremes are the incumbent vertical integration versus the municipal open access. It is probably safe to assume that both models will coexist and be further developed within a foreseeable future, and they may even cross-fertilize each other. The paper is organized as follows. Section 2 presents Acreo's work in the ALPHA (Architectures for fLexible Photonic Home and Access networks) project on dynamic access/aggregation networks for AON architectures. Section 3 discusses the Deutsche Telekom's (DT) activities within the OASE project and the proposed work for a consolidated network model at a lower TCO. Section 4 describes optical access research at Stanford and presents the Stanford University Access (SUCCESS) architectures, which enable graceful evolution from current to next-generation optical access networks

2. ACTIVE OPTICAL NETWORKS-BASED APPROACH (ACREO)

Active optical networks (AON, a.k.a. active or point-to-point Ethernet) are predominantly based on Ethernet that is thoroughly standardised within the IEEE concerning physical interfaces as well as control and management planes. Whereas end user transmission speeds are not an issue in AON (as opposed to PON) the next generation activities within the ALPHA project are focused on dynamic control and management in the access and distribution (a.k.a. aggregation or metro) network as well as integration with network control in the core network. Current access and aggregation networks mainly focus on having an aggregative function where traffic mainly flows between end users and the core parts of the network, see Fig. 1a). Also seen in this picture is the fact that a CO node is in principle the same as an aggregation switch and this leads to added flexibility in the AON Ethernet designs and in the dynamics of adding new customers. From an Ethernet point of view the networks are tree-shaped, but from an optical point of view rings are often deployed for redundancy. Meshed

topologies are possible but probably rare in real deployments. However, by having meshed structures in the access and integrating the access with the aggregation network, all the potential benefits of meshed networks may be achieved as discussed below.

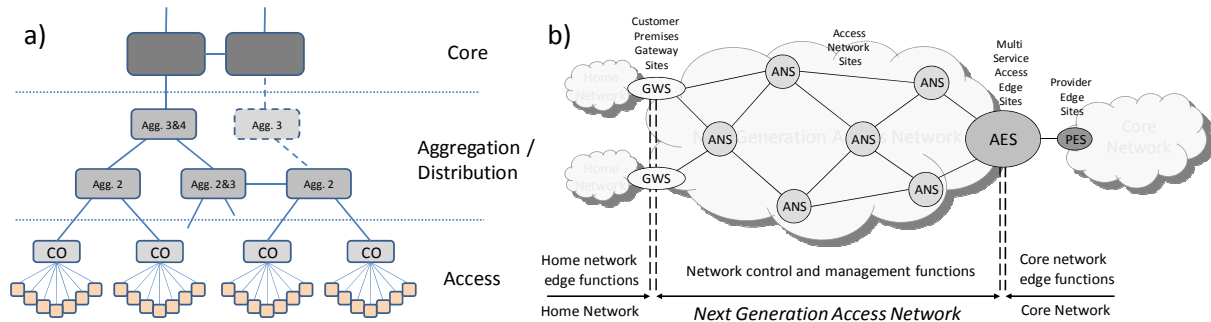

Figure 1: Where a) shows an idealised network comprising core, aggregation, and AON-based access network. A meshed structure may lead to higher dynamics and flexibility and a better integration between the network domains. And b) schematics of the proposed next generation access topology for AON with a higher degree of mesh possible. ANS stands for access network site and corresponds to the location where an ONT or higher levels of aggregation network elements might be located.

Within the ALPHA project Acreeo is investigating alternative access and aggregation architectures that are similar to the IETF multi protocol label switching (MPLS) approach. This approach allows for the network itself to handle resource allocation, i.e., a sort of auto configuration which gives the general benefits on scalability and resiliency of distributed systems. The triggering of such resource allocations are usually done through a centralised service management system that can allow for automatic or manual service provisioning, but it is also interesting with traffic driven resource allocation scenarios. As access bandwidths increase and core technologies are pushed outwards towards the access the next step is the integration of a dynamic optical layer. This could lead to a move from an MPLS control plane to a generalised MPLS (GMPLS) control plane that allows for multiple data plane technologies, i.e. a common control plane for the IP/MPLS and optical transport network (OTN) based distribution and core parts of the network. One of the benefits of operating a multi-technology based network with a common control plane solution is operational ease since end-to-end operations over multi-technology domains is less complex and leads to a lower TCO. This logic also applies to the access network since an operator can be in control of the access, aggregation and core networks, and leads to the idea of applying the IETF GMPLS control plane architecture for a multi-layer IEEE Ethernet data plane in access and aggregation network scenarios. The work done in ALPHA also aims at utilising all the benefits of new IEEE Ethernet standards while giving a complementary way of handling resource provisioning, loops, traffic control, locality of traffic, protection and restoration, and the possibility of moving into multi-technology scenarios. Another key goal is seeking a balance between centralised architectures and distributed architectures, e.g. understanding were centralised architectures has more leverage and vice versa. Currently this work suggest that it is beneficial to use the more dynamic technologies like AON in relatively densely populated environments, while long haul and less populated applications might be more suited for PON technologies. This means that the topology evolution of AON is quite different from PON. Where PON is moving towards highly centralised solutions with distances up to 100 km, AON would benefit from moving more towards utilising the resilience and dynamics given by a mesh and ring based topologies, see Fig. 1b) Acreeo aims at a continuation in refining this work in the OASE project which will be described in the following chapter.

3. OASE APPROACH TO NEXT GENERATION ACCESS NETWORKS

Current networks will undergo radical network changes due to transition from “services designed” networks (stovepipes) to open, standardised, multilayer Next Generation Networks (NGN) where all services will be delivered over one common network infrastructure enabled by separation of transport and service planes as depicted in Fig. 2.

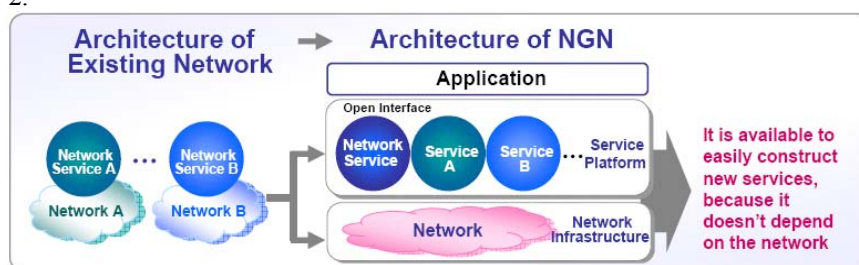

Figure 2. Change of the access networking paradigm towards open, multi-layer, next-generation networks [2].

This fundamental change in network structure and design is offering the possibilities of dramatically reducing total cost of ownership (TCO) and allowing for important opportunities to generate new revenue streams from innovative NGN services. On the other side, it will inevitably lead to new business opportunities, models and functional roles.

Besides this fundamental change in the overall network structure, the transition from a copper-based access network developed over decades to a new optical Fiber-to-the-Home (FTTH) based network infrastructure needs a radical reshaping of today's access networks. The top schematic in Fig. 3 depicts the trend of bringing the optical fiber closer to the customer. The access network from a central office (CO) up to the subscriber's premises in general consists of three main segments: From a central office where an optical line termination (OLT) is situated, the access network segment reaches up to the building's termination point. In all these scenarios, however, the location of the optical line termination (OLT) is assumed to remain unchanged at today's central office (CO) locations. At a CO several access links are terminated and a further aggregation of the incoming traffic is performed within the aggregation network. In this metro-access region the aggregation may be done in several stages.

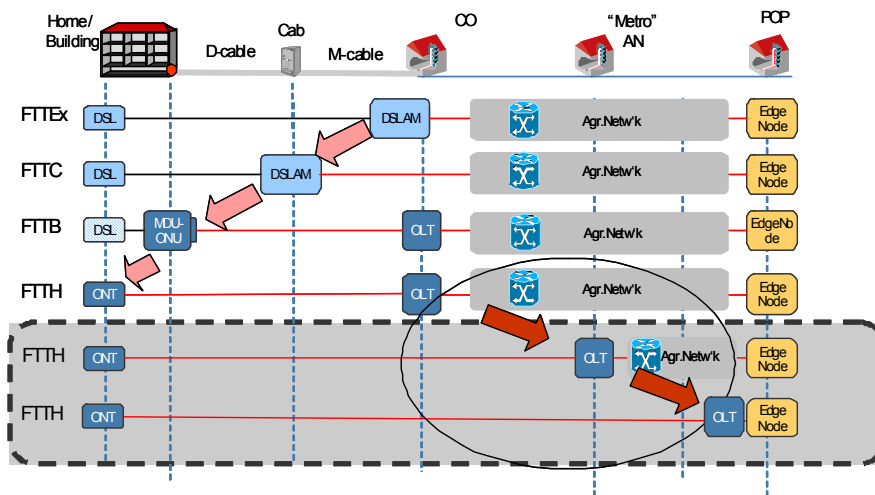

Figure 3. Potential migration towards next generation optical access network.

The shift of the OLT towards the Edge node will in an ideal case lead to a pure passive central office. This in general is an approach which is sometimes referred to as node or network consolidation. From an operational point of view, one expects to have significantly lower operational expenditures (OpEx) in such a consolidated network [3-4]. However, this also has a significant impact on the potential of the deployed technologies. Most likely, the distances to be bridged between the customers and the new OLT locations will become longer. Also, the service areas and the total number of households served by one OLT location will significantly increase. This will affect the principal interdependencies of the network structure such as distribution between the aggregation network and the access network, the associated link length, node functionalities and the resulting cost dependencies. To investigate these dependencies in detail the project OASE started January 2010 for a three year period. OASE aims at the assessment and development of next-generation optical access (NG-OA) network architectures and systems configurations for the "2020" time horizon based on European requirements. OASE will lead to the development of NG-OA architectures and systems enabling ≥ 1000 customers per feeder fiber, ≥ 100 km reach, and ≥ 1 Gb/s per customer at economical prices. This is enabled by the study of current and future NG-OA requirements from economic, business, operational and regulatory perspectives, followed by the identification of possible network architectures, energy-efficiency metrics and migration strategies. Systems and architecture concepts like PON, AON, WDM-PON and Hybrid approaches in star, ring or mesh configurations will be analyzed in terms of cost and technical factors. Relevant findings will be confirmed in lab environments. Finally, OASE will contribute to standardization.

4.1 SUCCESS architectures: graceful evolution to next-generation optical access (Stanford University)

Future optical access networks can be categorized into two generations: second- and third-generations [5]. Second-generation optical access networks will facilitate graceful evolution to higher bandwidth and data rates. Rather than replacing existing services, new (such as 10Gbps or CWDM signals) and existing signals must co-exist over the same fiber infrastructure. To achieve graceful evolution from current- to second- generation optical access networks, service providers can choose to deploy prearranged network equipment to launch the upgrade signal at new wavelengths. Alternatively, they can choose to overlay new signals using either sub-carrier multiplexing (SCM) or spectral shaping techniques. Third-generation optical access networks will employ more radically new architectures and technologies to support much higher capacity and/or facilitate network

scalability to satisfy longer-term demand. While there are many proposals focusing on fulfilling this purpose, few architectures can offer graceful evolution from current-generation PONs. SUCCESS architectures developed by our laboratory at Stanford University support graceful evolution using novel components and architectures. In SUCCESS-DWA (dynamic wavelength allocation), no change in the optical distribution network is required while evolving toward WDM PONs. In this approach, an arrayed waveguide grating at the central office, combined with wavelength filters at ONUs (Fig. 4.1), provides a highly scalable solution to hybrid TDM/WDM PONs and achieves a high statistical multiplexing gain. In SUCCESS-HPON (hybrid TDM/WDM PON), distribution nodes are replaced with waveband thin-film filters and arrayed waveguide gratings to simultaneously support legacy TDM PONs and new WDM PONs (Fig. 4.2). In this approach, multiple optical tree networks are consolidated into a ring topology. Central light source is further used to eliminate light sources at ONUs. Efficient scheduling algorithms have been developed by our groups for both architectures in order to share tunable components among many users and provide QoS.

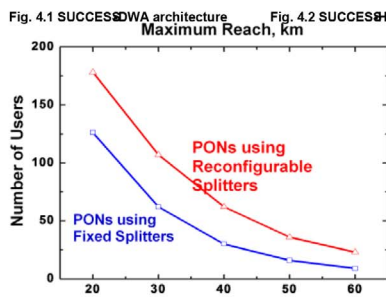
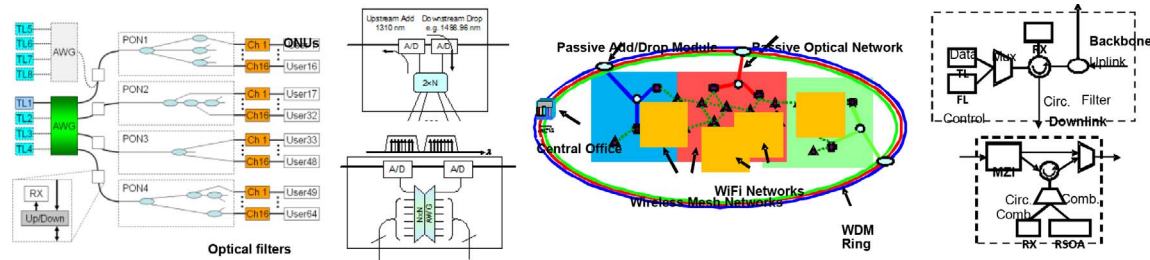

Fig. 4.5 Comparison of reach-user scalability

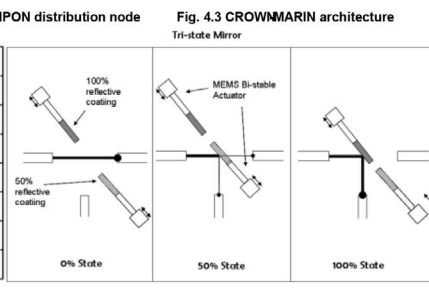

Fig. 4.6 Tri-state power attenuator operation

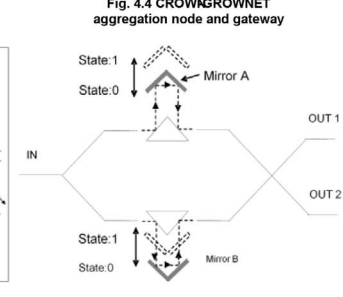

Fig. 4.7 Bi-stable Mach-Zehnder interferometer

4.2 Wireless technology integration in next-generation optical access network (Stanford University)

Next-generation wireless access infrastructures will require scalable and robust fiber backhaul to support increased aggregate bandwidth and a larger number of fiber drops. Recent proposals in this area investigate integrated PON-wireless architectures to replace existing point-to-point copper-based backhaul solutions. However, current PON infrastructure cannot provide dense fiber deployment over a large scale. CROWN architectures[6] support robust and scalable backhaul to metropolitan-wide area using reconfigurable optics and novel architectures. In CROWN-MARIN (metro and access ring integrated network), multiple PON distribution networks are consolidated over a reconfigurable WDM ring backhaul (Fig. 4.3). Passive add drop modules are deployed in the field to preserve passive nature of the distribution network and wavelength reconfigurability is achieved using tunable filters at the ONUs. Reconfigurable power/wavelength routers are used to deploy higher bandwidth and achieve greater density of routers along the fiber grid network (Fig. 4.4).

4.3 Novel non-volatile optical device for next-generation optical access network (Stanford University)

Reconfigurable power/wavelength routers are important for next-generation optical access networks. Reconfigurable router can allow flexible distribution of optical power and wavelength to enable greater reach-user scalability. The key challenge in building these reconfigurable routers is keeping the device passive. Fig. 4.6 shows an implementation of a tri-state power attenuator using two bi-stable mirrors moving along the same axis. Fig. 4.7 shows the implementation of latchable Mach-Zehnder interferometer using bi-stable fold-back MEMS actuators. The non-volatile MZI architecture will enable flexible power and wavelength distribution as required by next-generation optical access networks.

5. CONCLUSIONS

Large Bandwidth at a relatively low cost has resulted in the deployment of optical access networks. In the coming years with increasing demands for bandwidth from end users, the current architectures have to evolve to support the requirements of the future. Two different evolution paths have been outlined here: Whereas next generation activities within PON attempts to reduce the aggregation network and decrease the number of central offices, the next generation AON activities aim at preserving a relatively large number of CO's and thereby

creating more dynamics in the network. The means are different, but the aim is the same: to reduce the total cost of ownership.

Acree's AON architecture is a promising solution which envisages the integration of current access technology with control frameworks such as GMPLS and possibly migration to meshed access networks providing redundancy and dynamics, thereby being well-suited for increased peer-to-peer usage. DT's proposed OASE project is another step in this direction, where drastic reduction in the TCO of a network by consolidating current PONs could result in increased economic viability of next generation optical access networks. The evolution to next generation access architectures requires enabling technologies which have been proposed under Stanford University's SUCCESS project that will allow for graceful migration. The components that could help realize these functionalities have also been presented. Integration of the three aforementioned approaches in some form could provide the basis for next generation architectures that could help realize increase the penetration of broadband access to households and end users. Finally it should be observed that the choice of specific access technology strongly depends on the business model, and that there will be no one-size-fits-all. This paper outlined from a European and an American perspective two possible scenarios for next generation optical access that may well coexist in the future.

ACKNOWLEDGEMENTS

The Acree research received funding from the European Community's Seventh Framework Programme (FP7) under grant agreement 212 352 ALPHA. DT's research was performed within the OASE project which received funding from FP7 under grant agreement 249 025". The research under Stanford University is funded by Motorola, KDDI, STMicroelectronics, and Huawei.

REFERENCES

- [1] P. Chanclou *et al.*, "Overview of the optical broadband access evolution," *IEEE Commun. Mag.*, vol. 44, pp. 29-35, Aug. 2006.
- [2] K. Kenyoshi, Electron. ITU Standardization Forum "Bridging the ICT standardization and development gap in developing countries," (1997) pp. 5.
- [3] R.P. Davey, D.B. Payne, D. Nessel, P. Tomlinson, T. Gilfedder, P. Chidgey, and A. Rafel, "Long-reach access and future broadband network economics," *European Conference on Optical Communications (ECOC)*, Berlin, Germany (3), 271-274 (2007).
- [4] C. Lange, D. Breuer, R. Hülsermann, "Cost effectiveness of site reduction in optical access networks: A CapEx based comparison of different technologies," *International Conference on Transparent Optical Networks (ICTON)*, São Miguel, Azores, Portugal (2009).
- [5] L. Kazovsky *et al.*, "Next-generation optical access networks," *IEEE/OSA J. Lightwave Tech.*, vol. 25, no. 11, pp. 3428-3442, Nov. 2007.
- [6] W.-T. Shaw, S.-W. Wong, N. Cheng, K. Balasubramanian, C. Qiao, and L. Kazovsky, "Reconfigurable optical backhaul and integrated routing algorithm for load balancing in hybrid optical-wireless access networks," *IEEE International Conference on Communications (ICC 2008)*, Beijing, China, May 2008, pp. 5697-5701.