

# NGOA network deployments: improving the business case for existing and new actors

**Bart Lannoo, IBBT**

**Koen Casier, Sofie Verbrugge, Jan Van Ooteghem**

ECOC 2010 workshop

September 19, 2010



# Business roles: “what is done?”

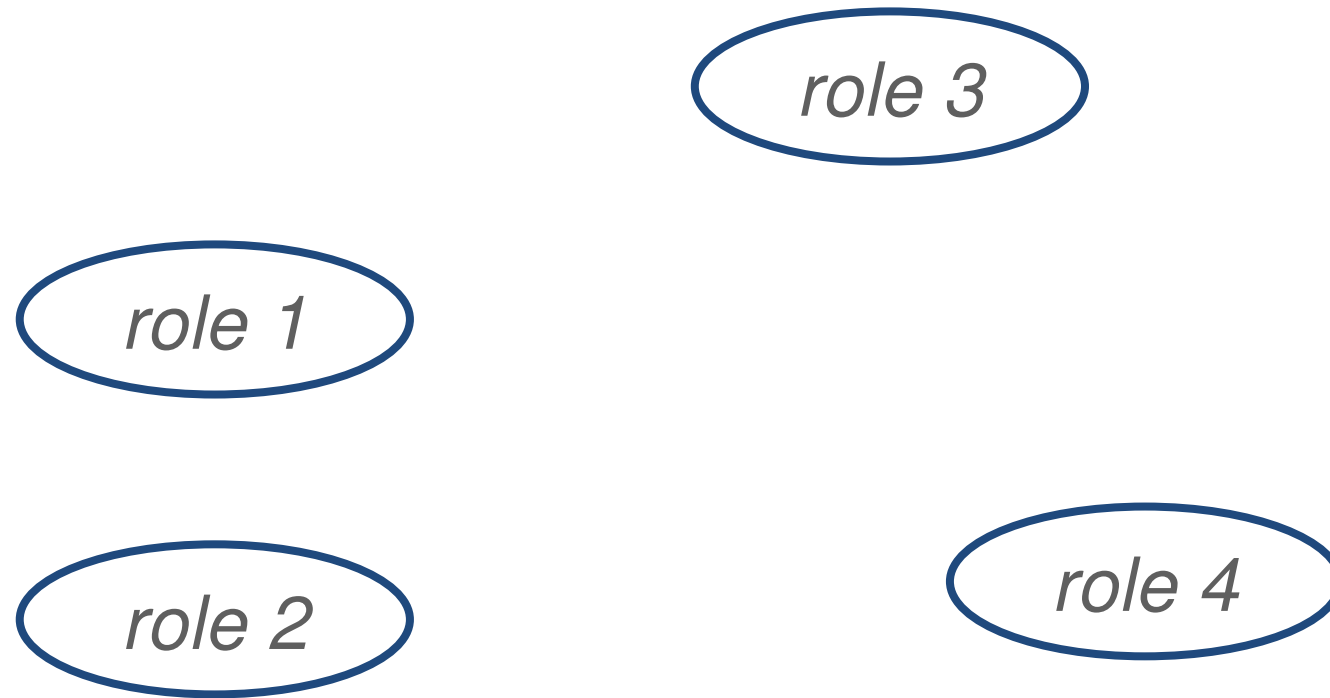

# Business actors: “by whom”

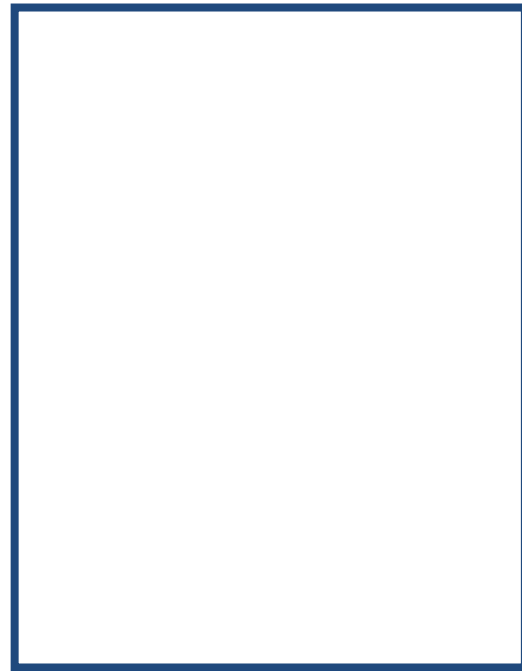

actor A



actor B



actor C

# Value network: “mapping actors to roles”

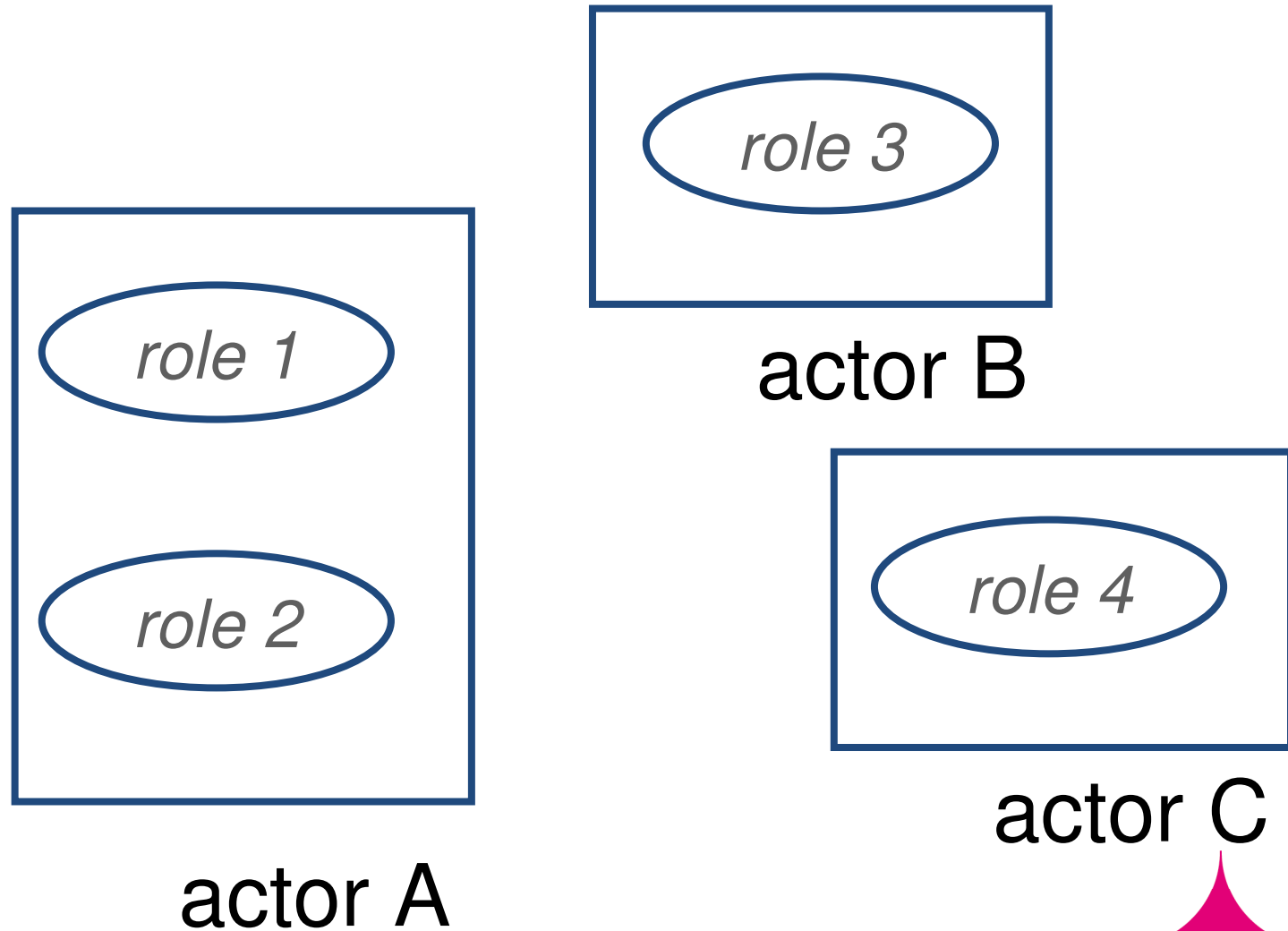

# Value network: “indicating value streams”

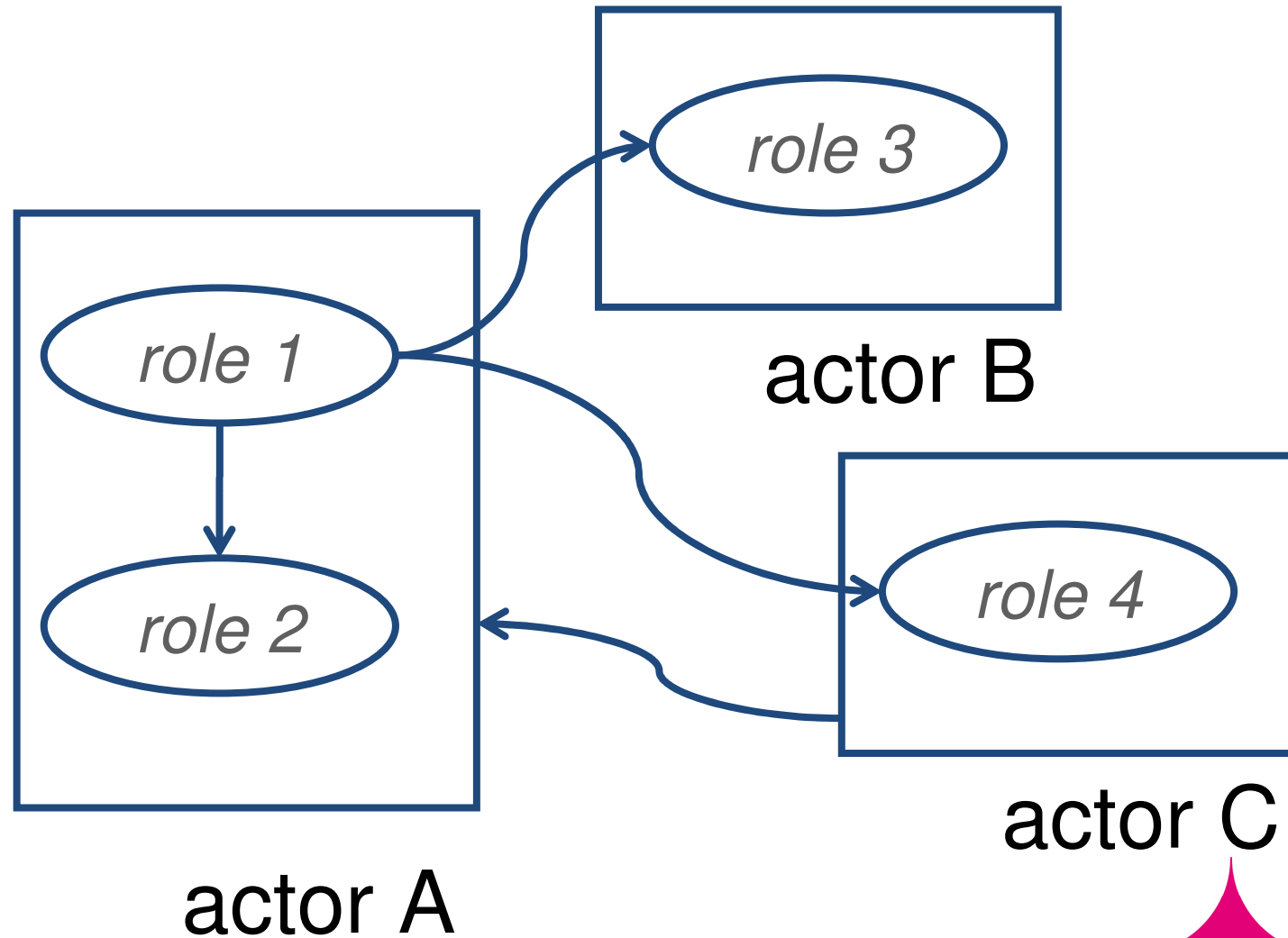

# FTTH Business Roles and Actors

# “Network layered” business roles

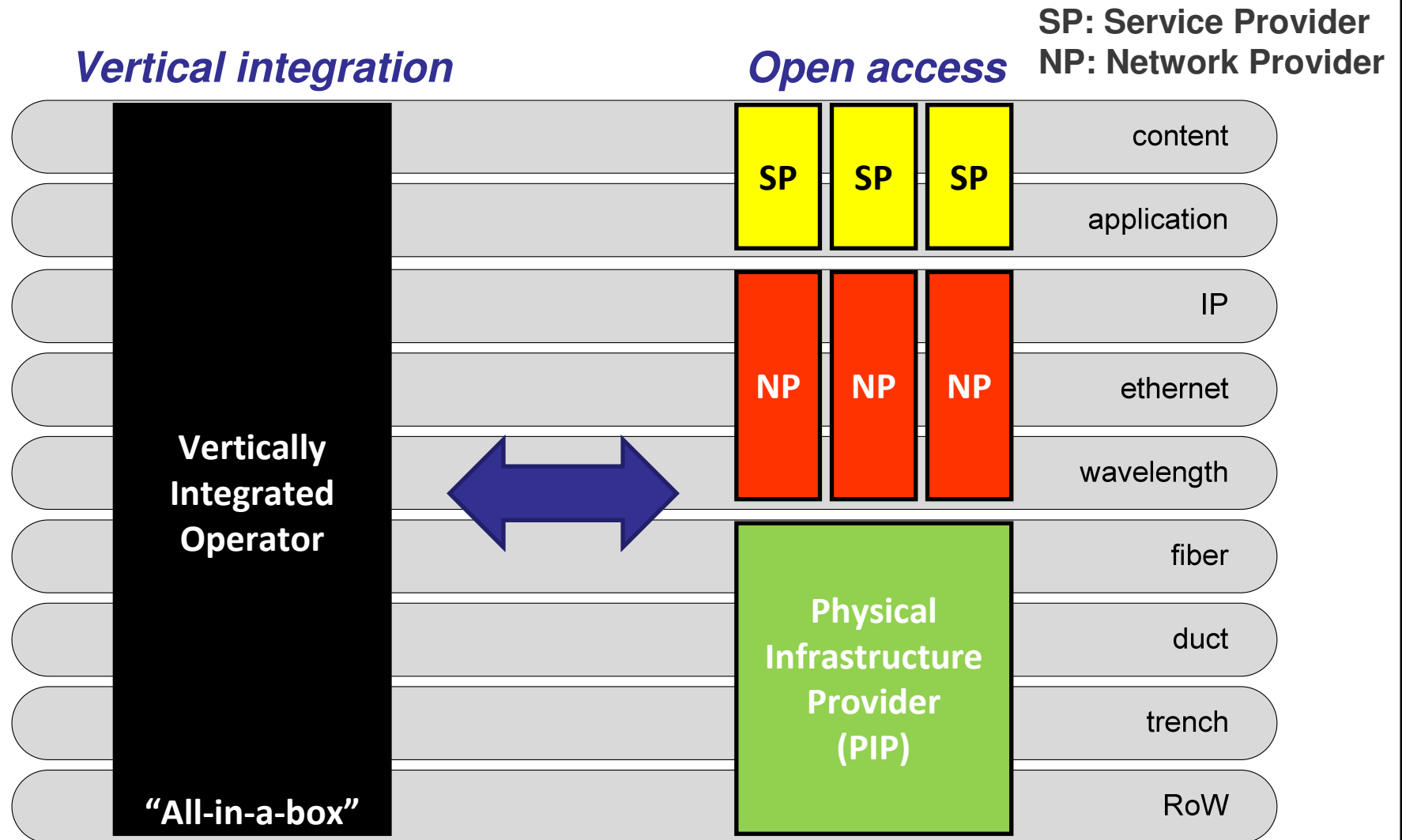

# Lifecycle business roles

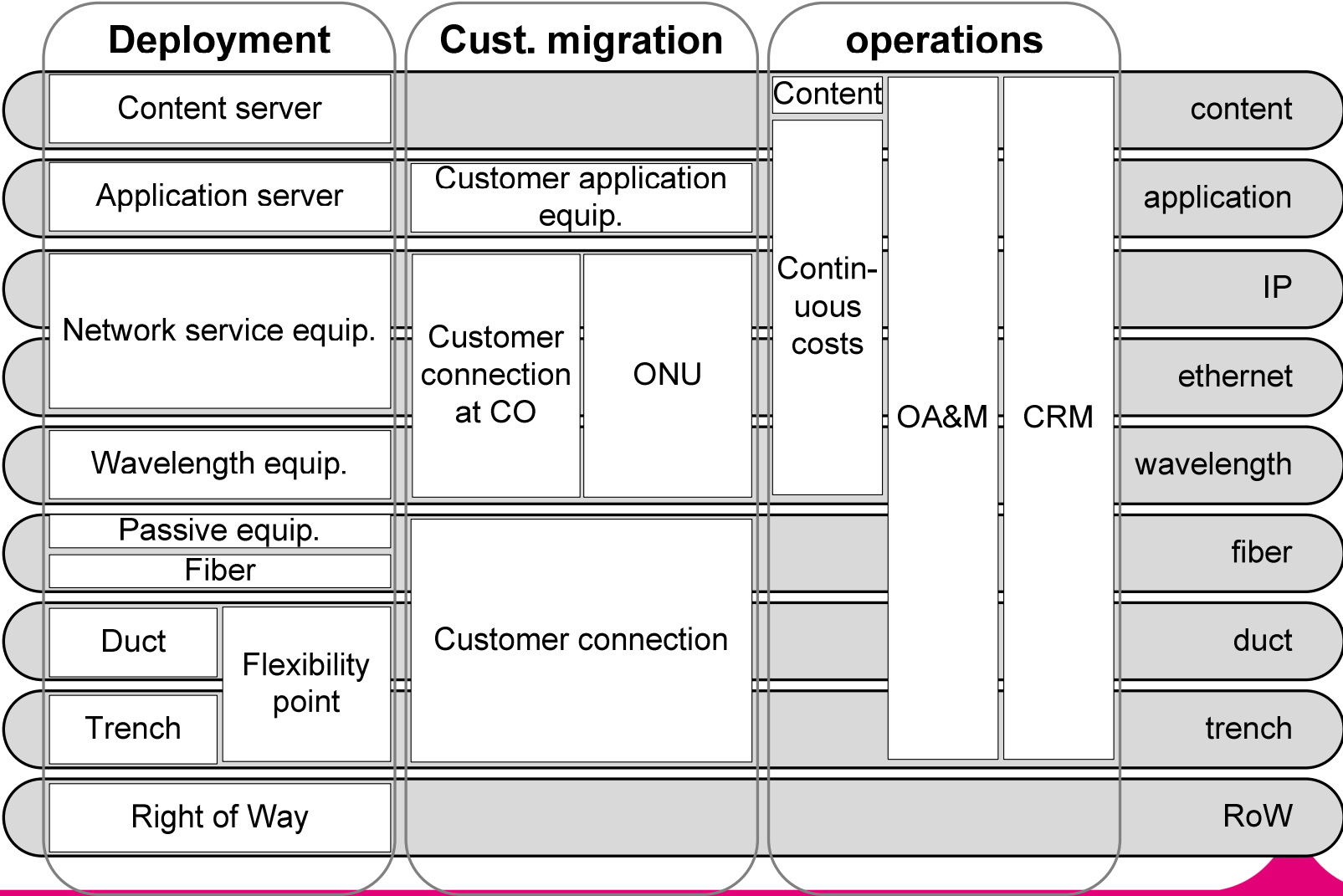

# Actors mapped to the roles

- Existing business actors for broadband access networks
  - Incumbents
  - Cable operators
  - Network providers
- New business actors for broadband access networks
  - Municipalities
  - Service providers
  - Housing companies
  - Vendors

# Lifecycle business roles: municipalities

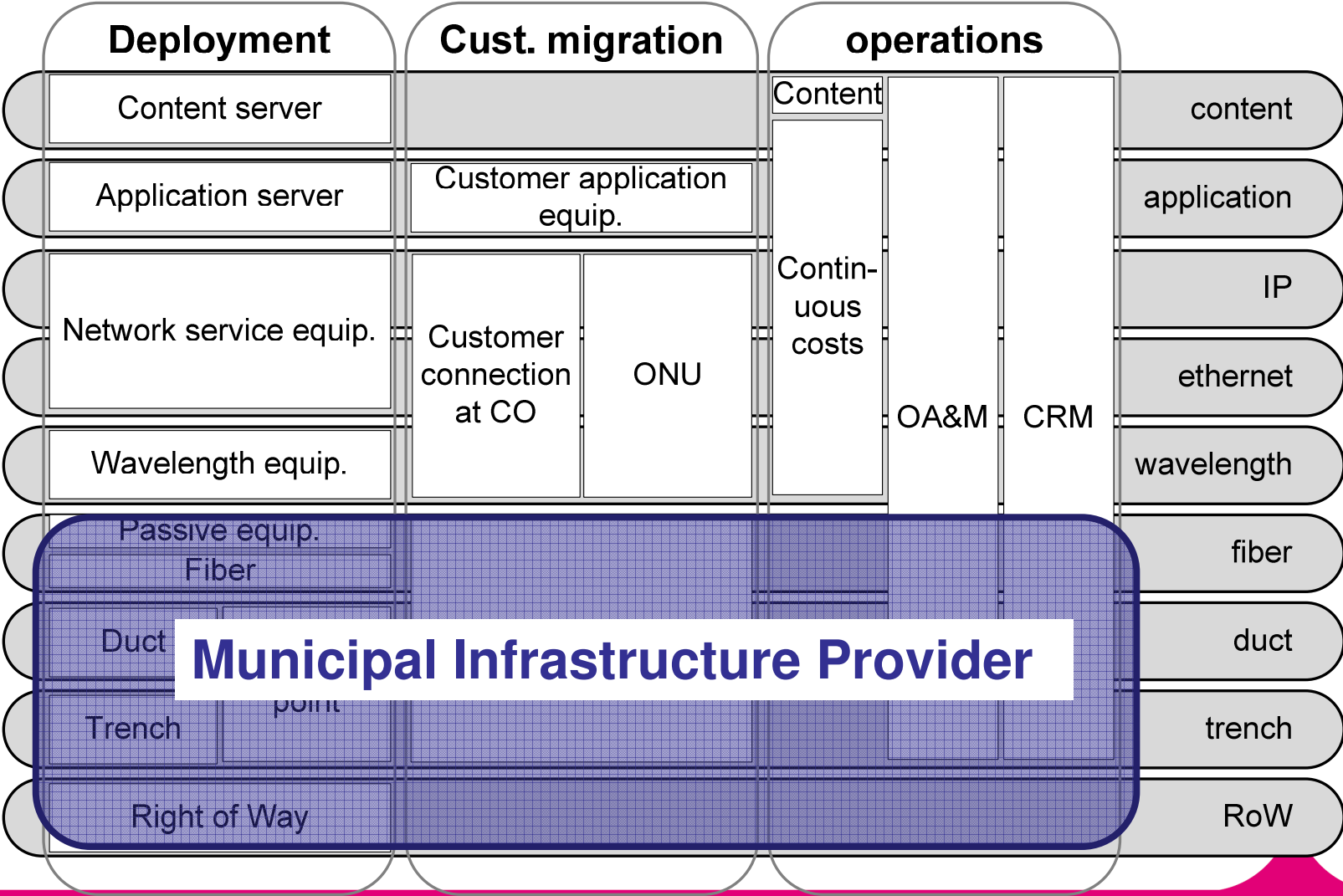

# Lifecycle business roles: municipalities

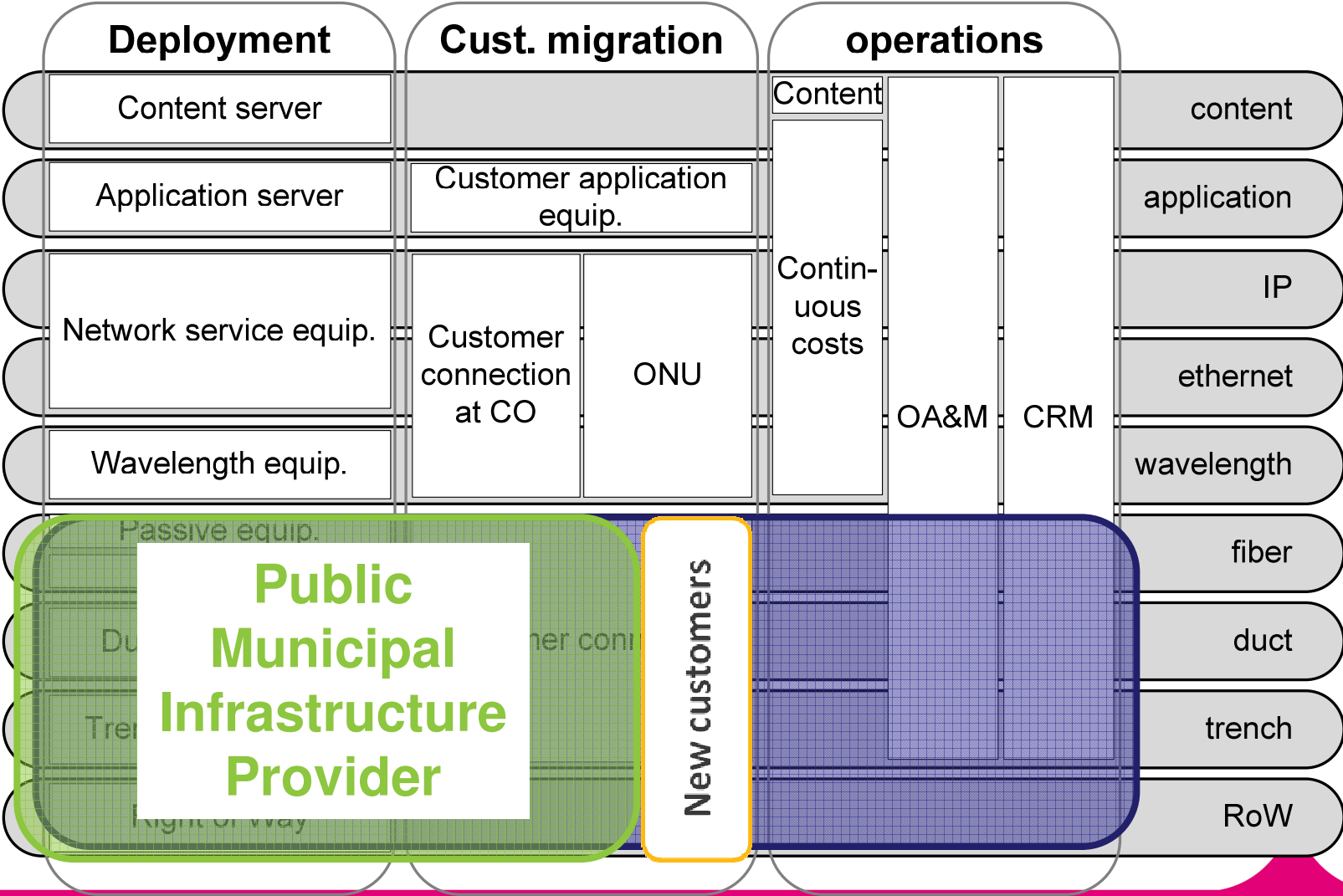

# Lifecycle business roles: municipalities

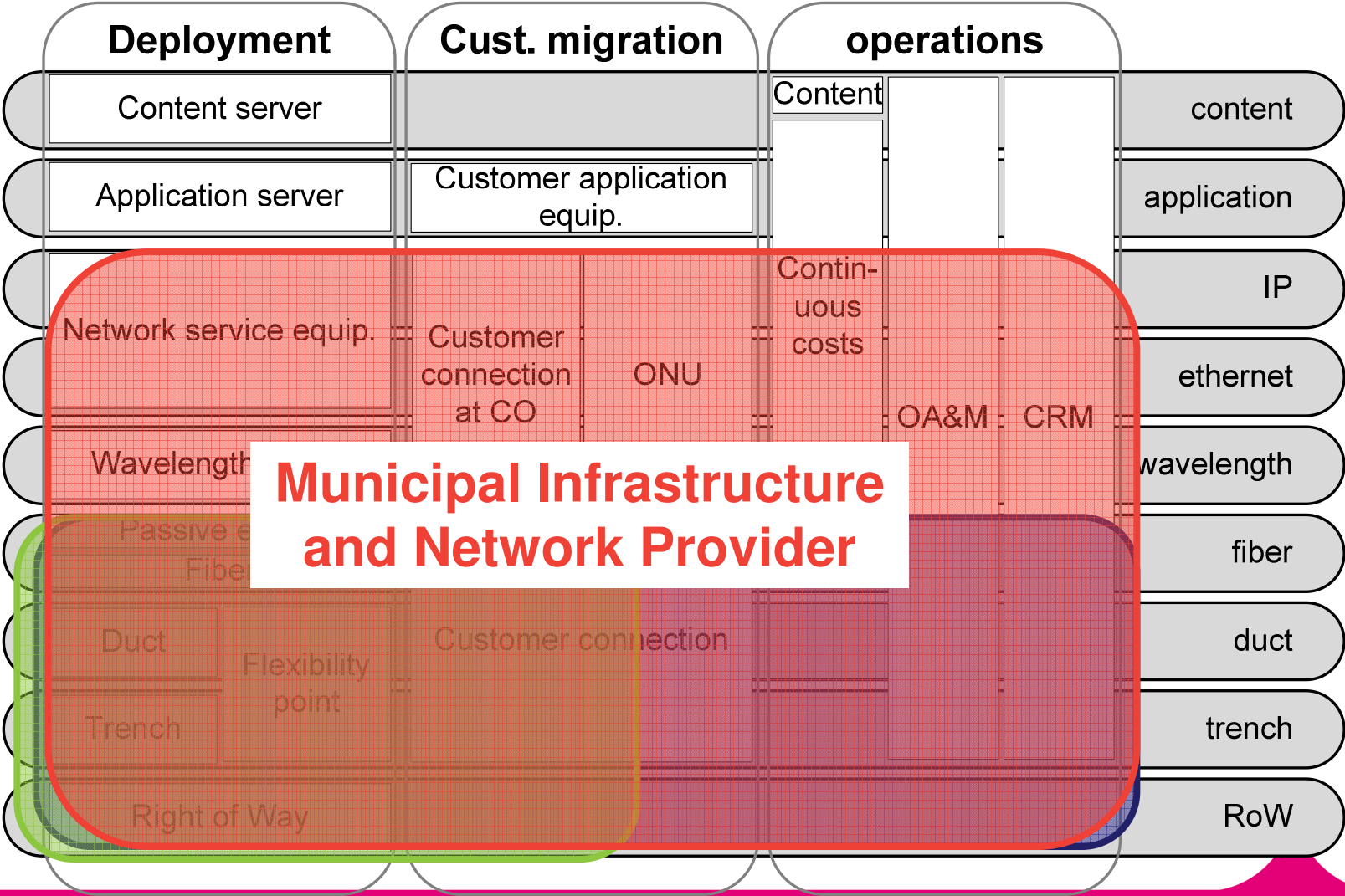

# Lifecycle business roles: service providers

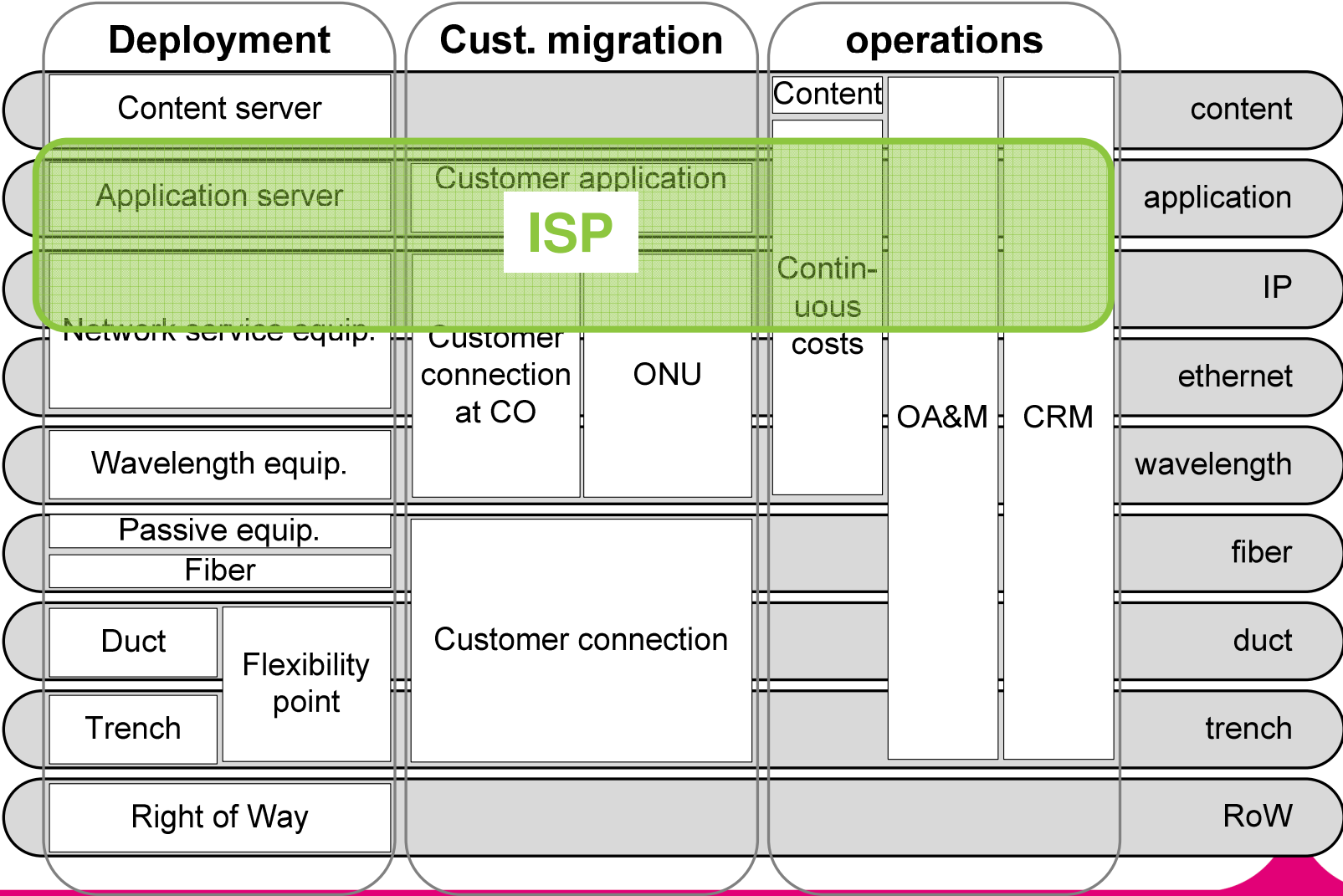

# Lifecycle business roles: service providers

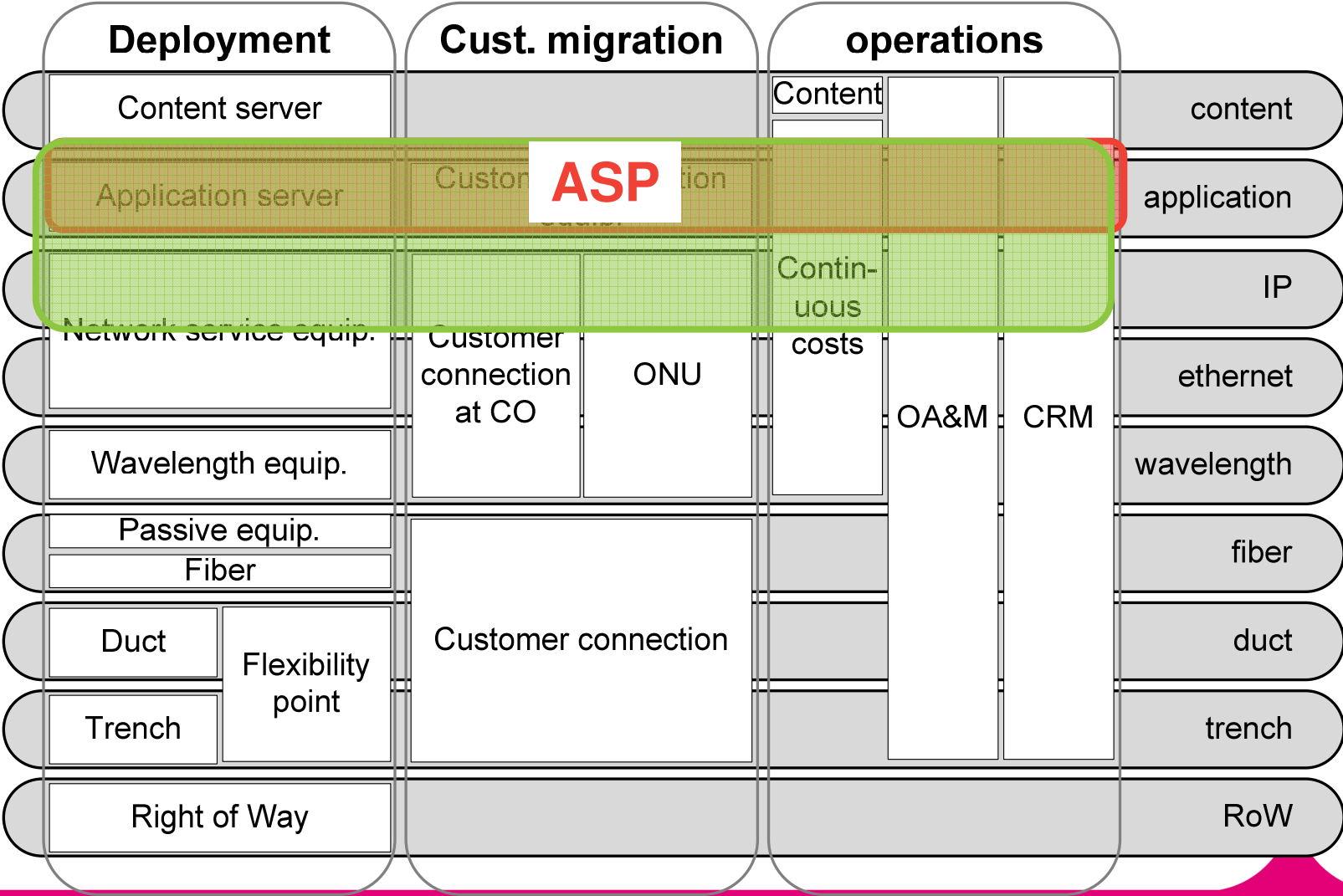

# Lifecycle business roles: service providers

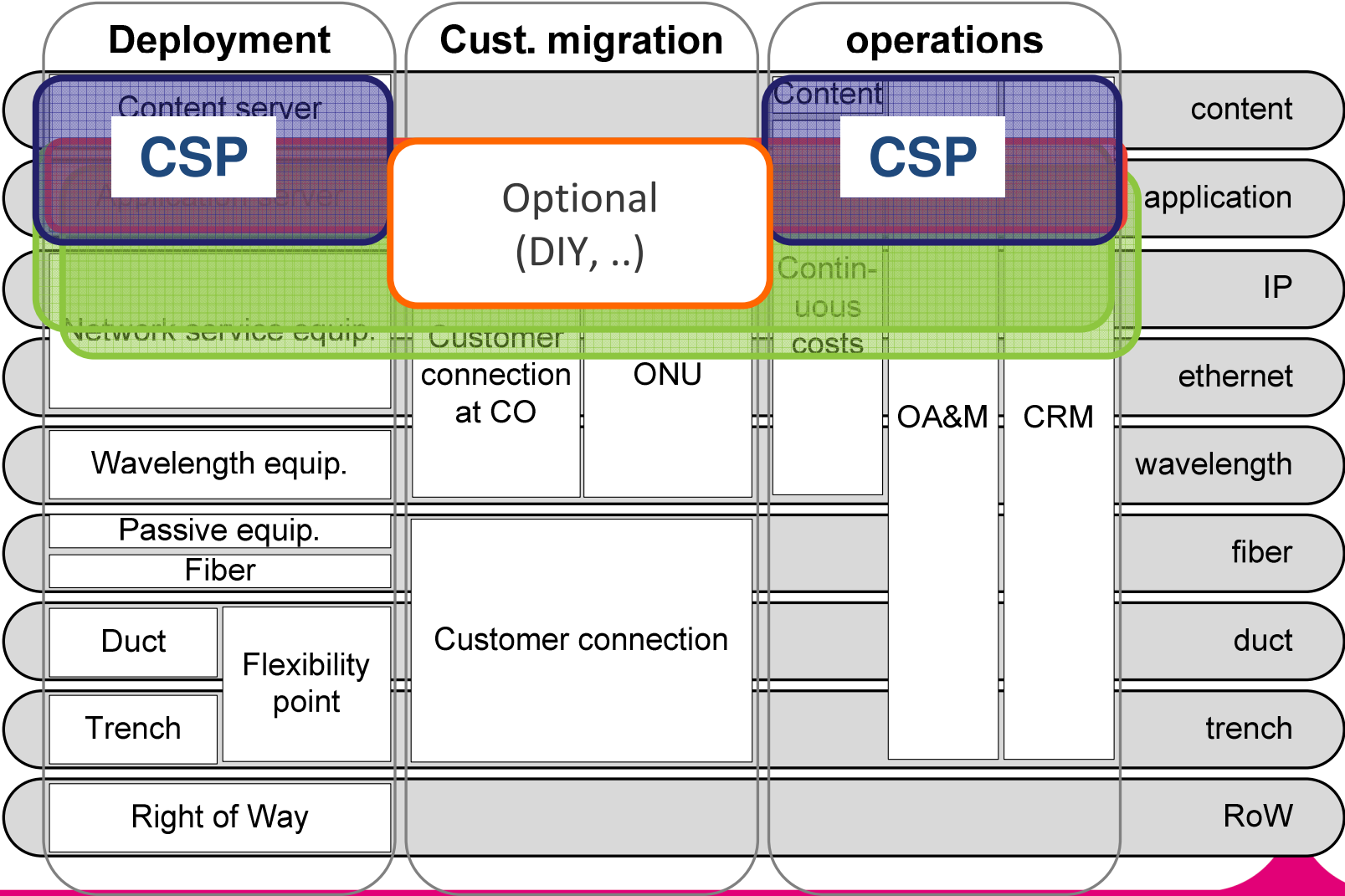

# Optimize the FTTH Business Case in a holistic way

Step 1 – Connect the Best Customers

Step 2 – Reduce the Installation Costs

Step 3 – Control the Operational Costs

# STEP I: Connect the best customers

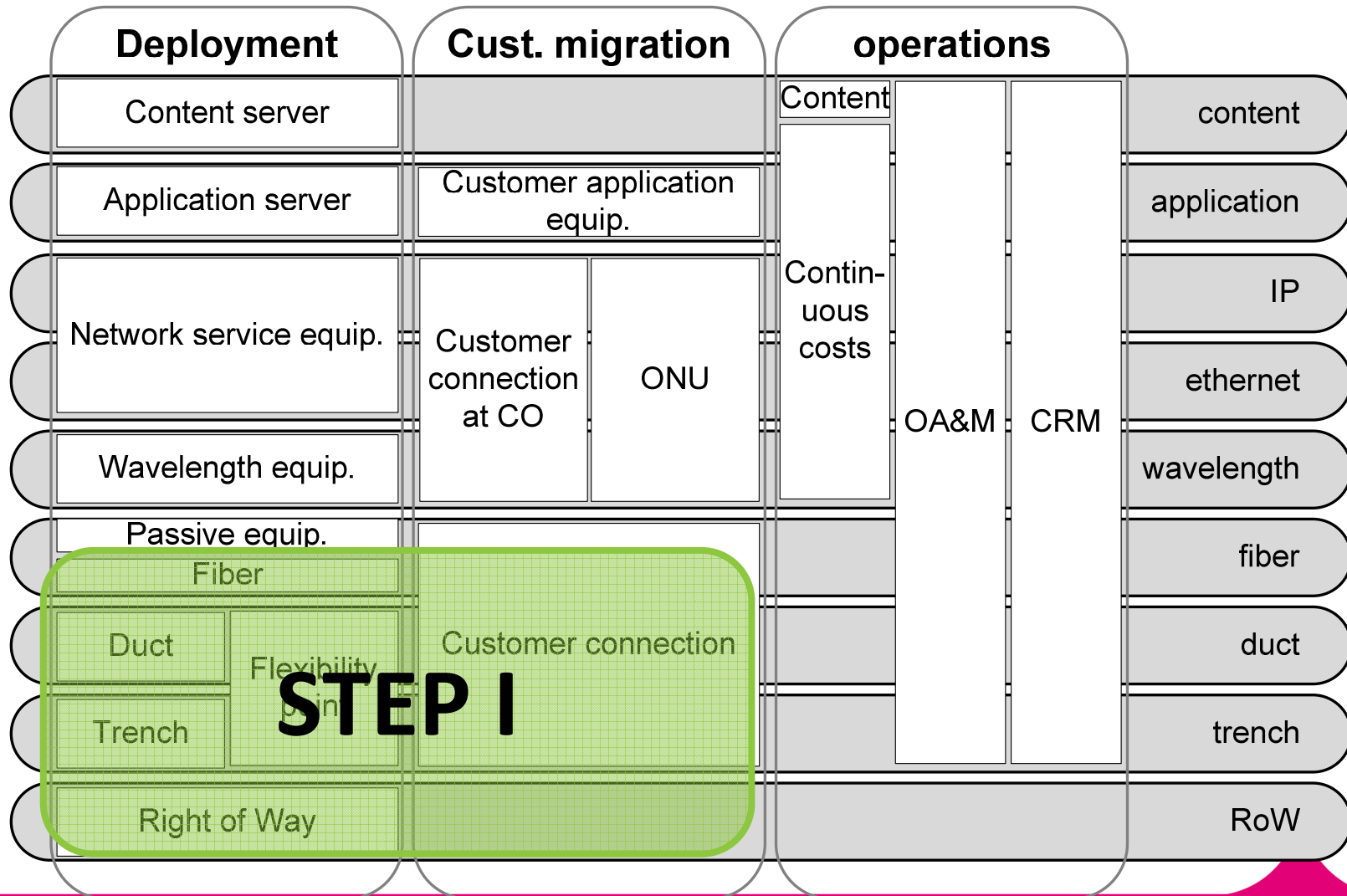

# Optimize the FTTH Rollout Strategy

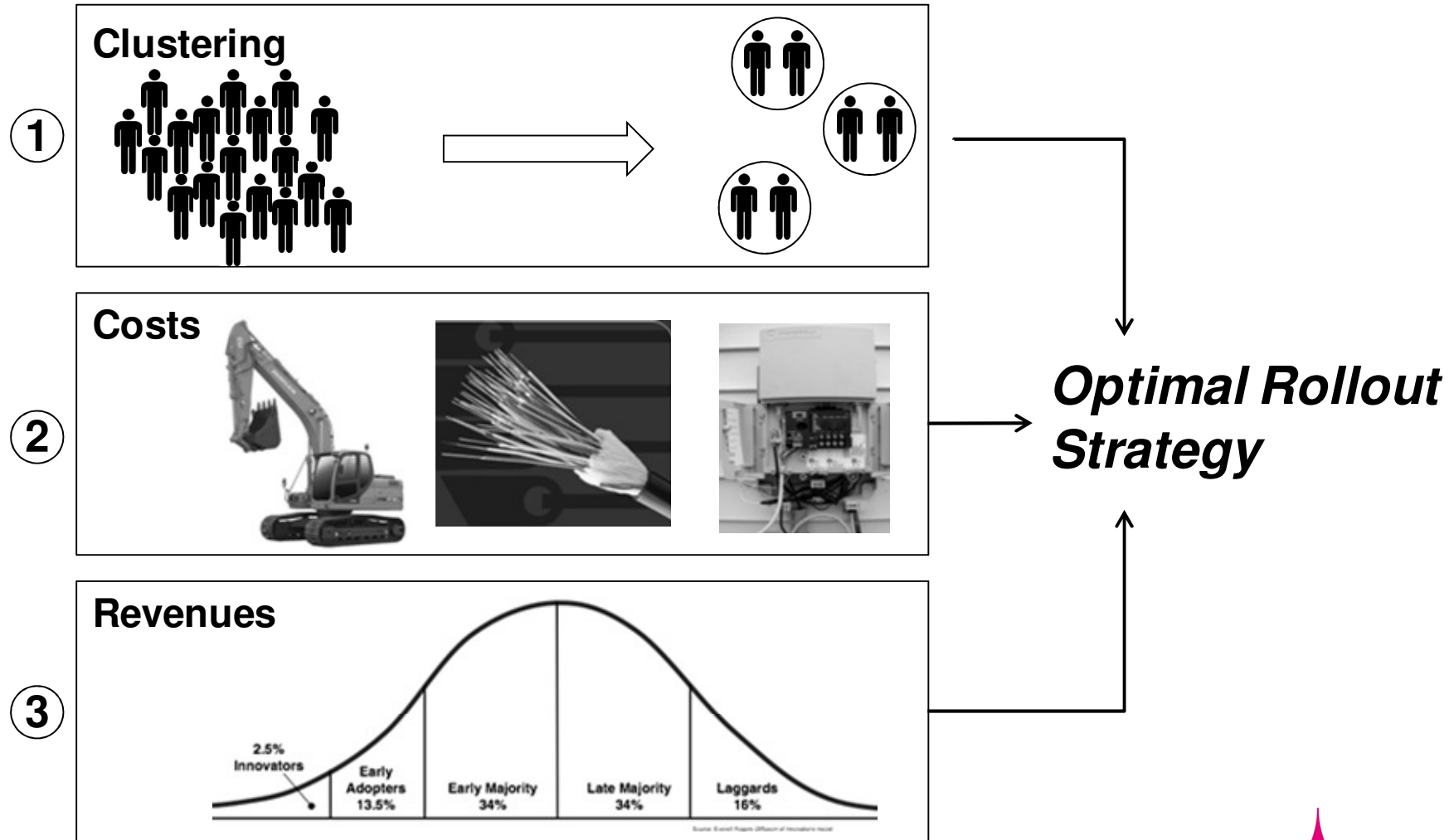

# Large Benefits When Using Geomarketing

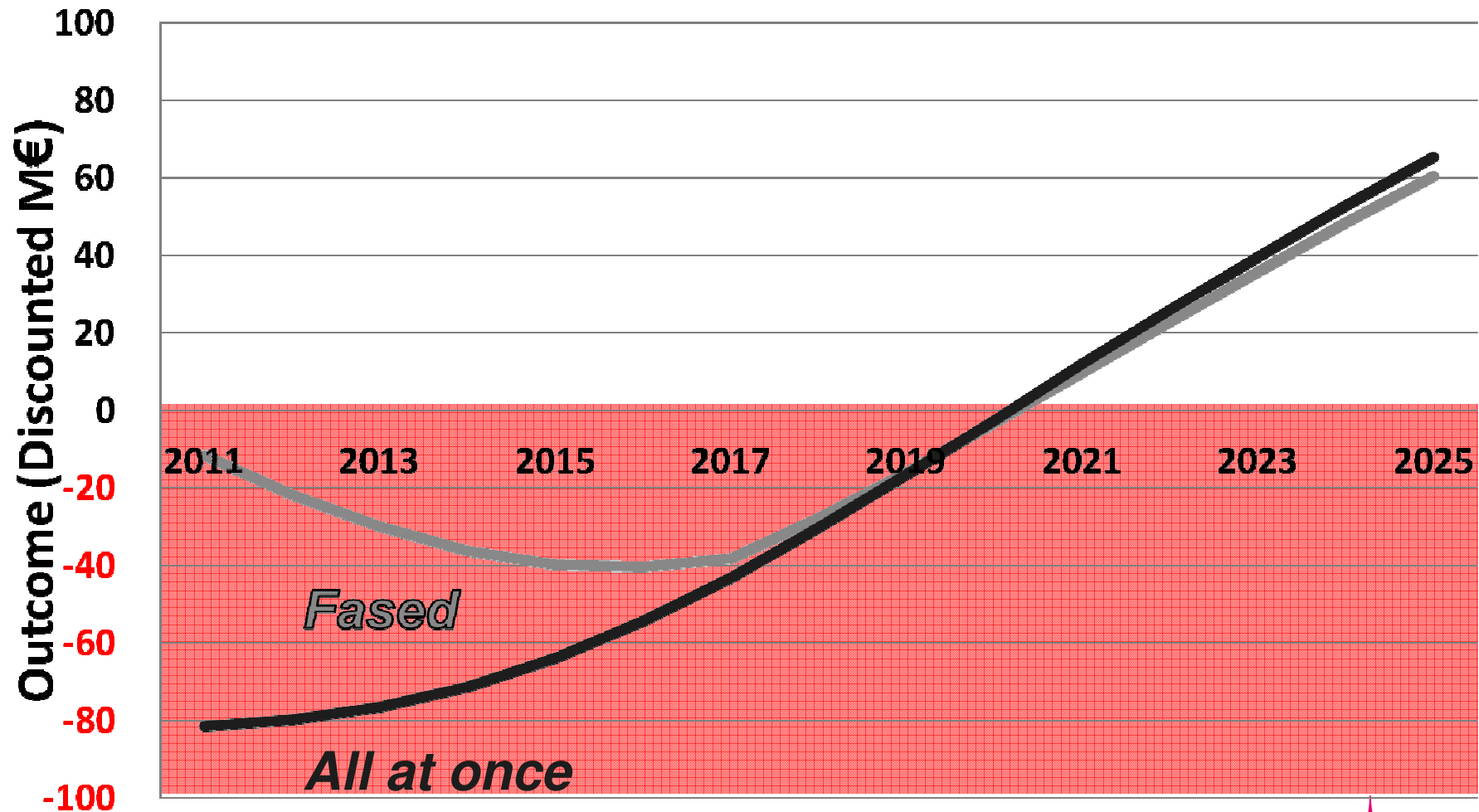

# Large Benefits When Using Geomarketing

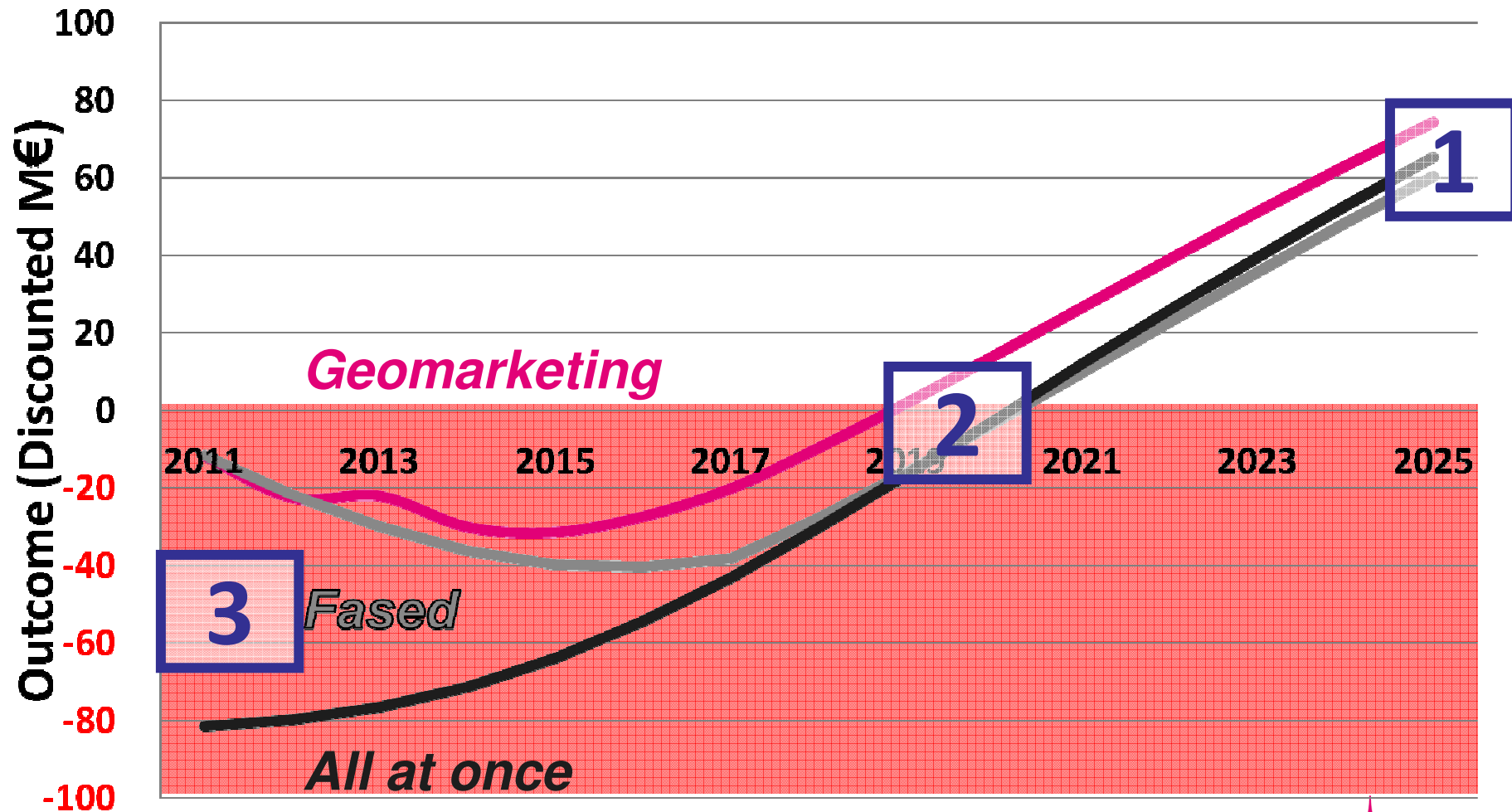

# STEP II: Reduce the installation costs

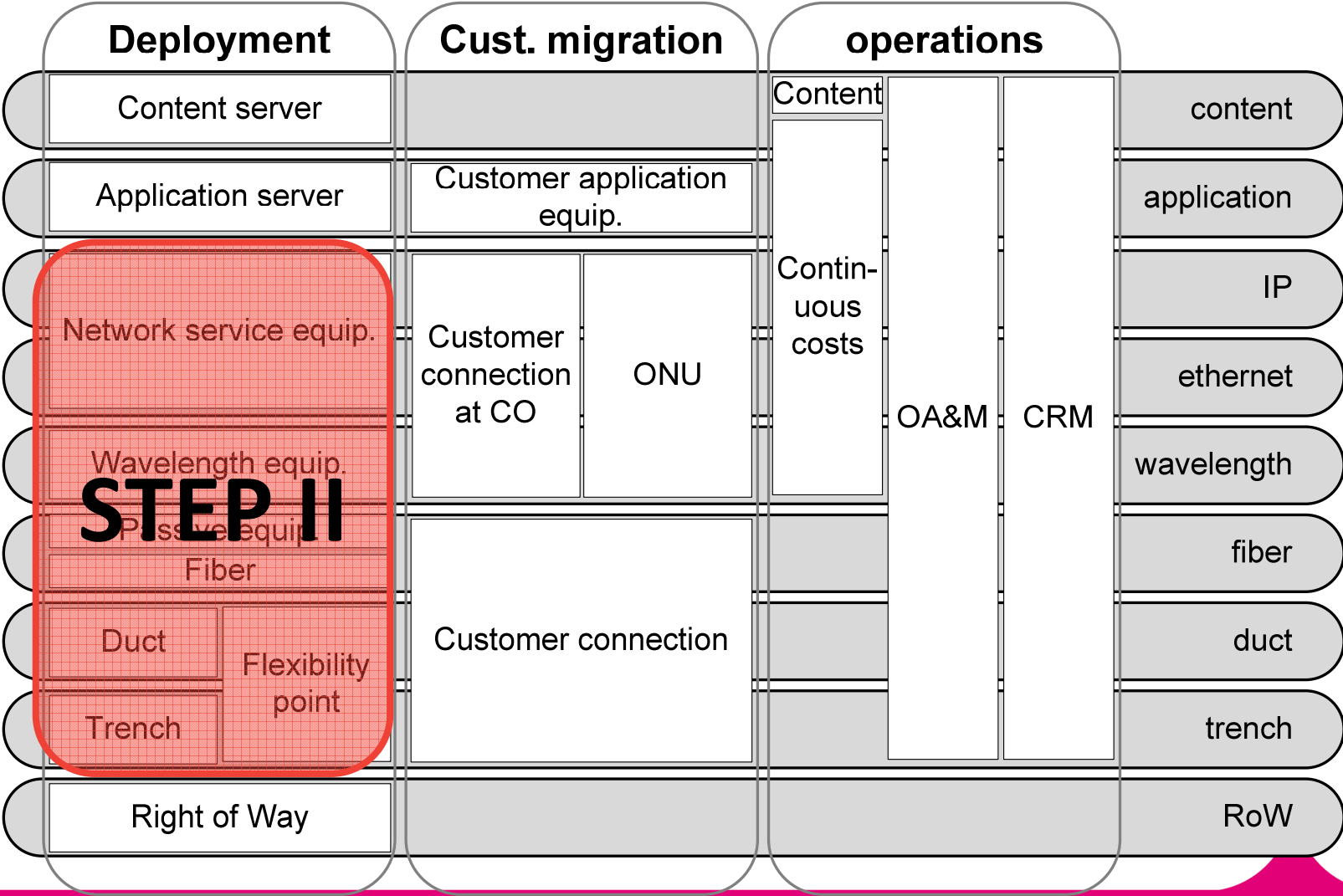

# Optimize the Installation Path

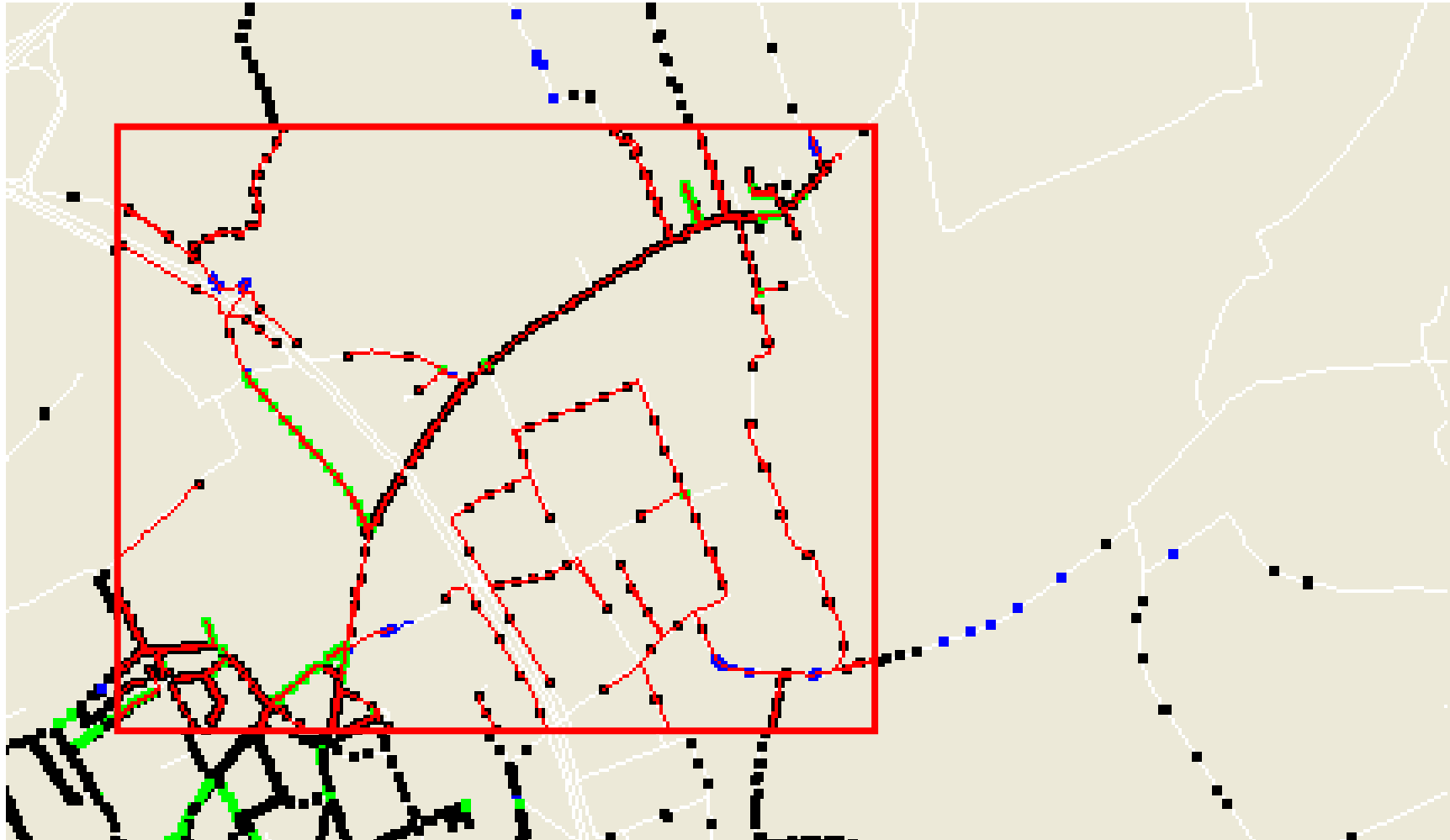

# Optimize the Installation Method

## Fully-buried



- + Robust invisible
- Expensive road works



## Fiber blowing/pulling



- + Cheap & Install if used
- Ducts available

## Aboveground



- + Fast Cheap
- Vulnerable Regulations

# Cooperating with other Infrastructures

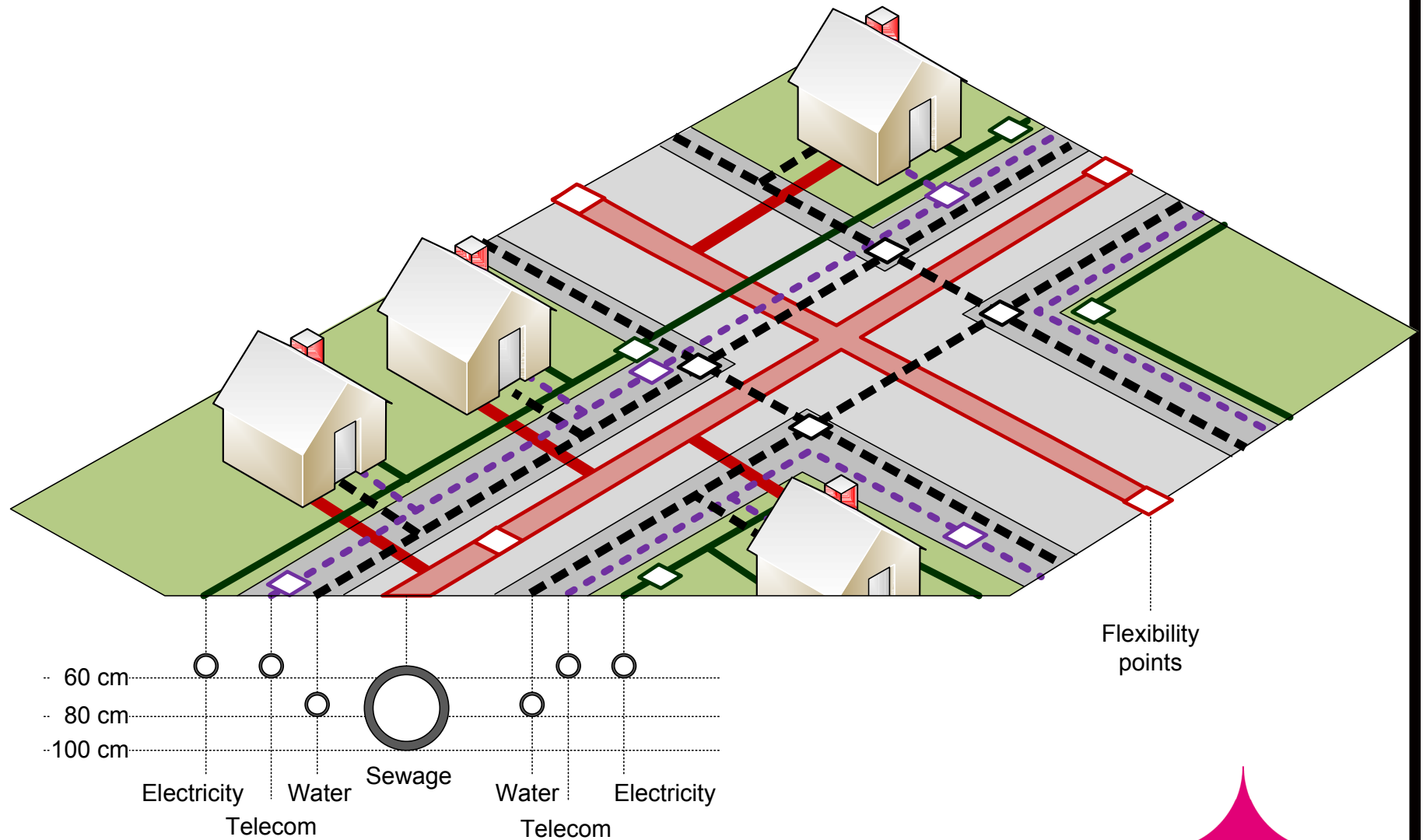

# Cooperating with other Infrastructures

Electricity Fiber

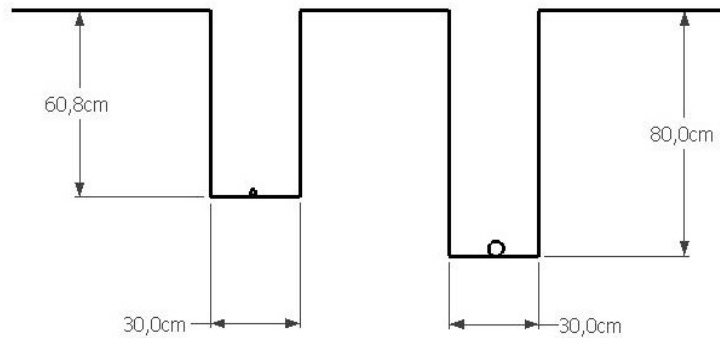

Cooperate

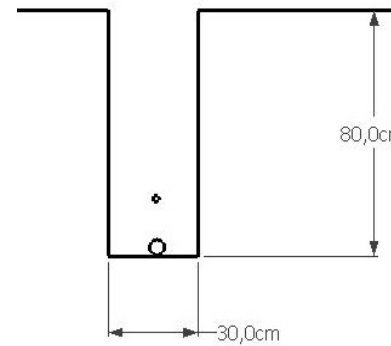

Fiber Gas

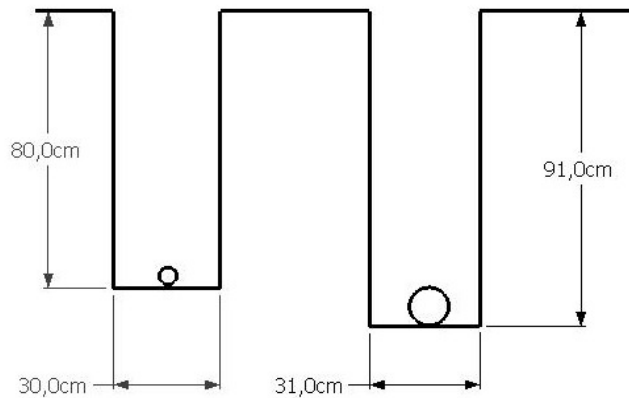

Cooperate

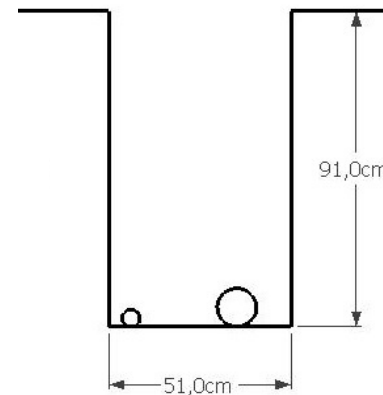

# The Gain in Cooperating

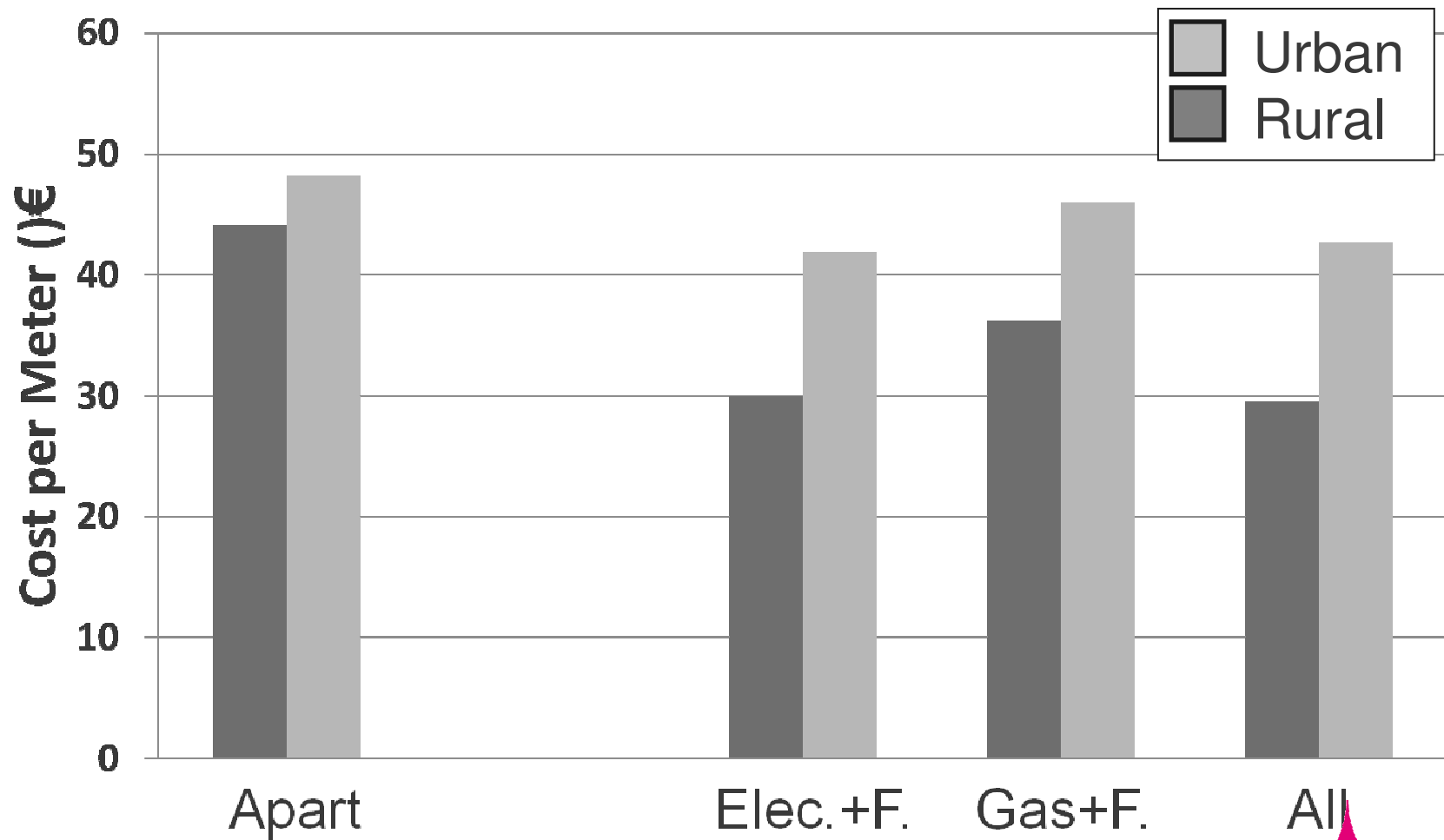

# STEP III: Control the operational costs

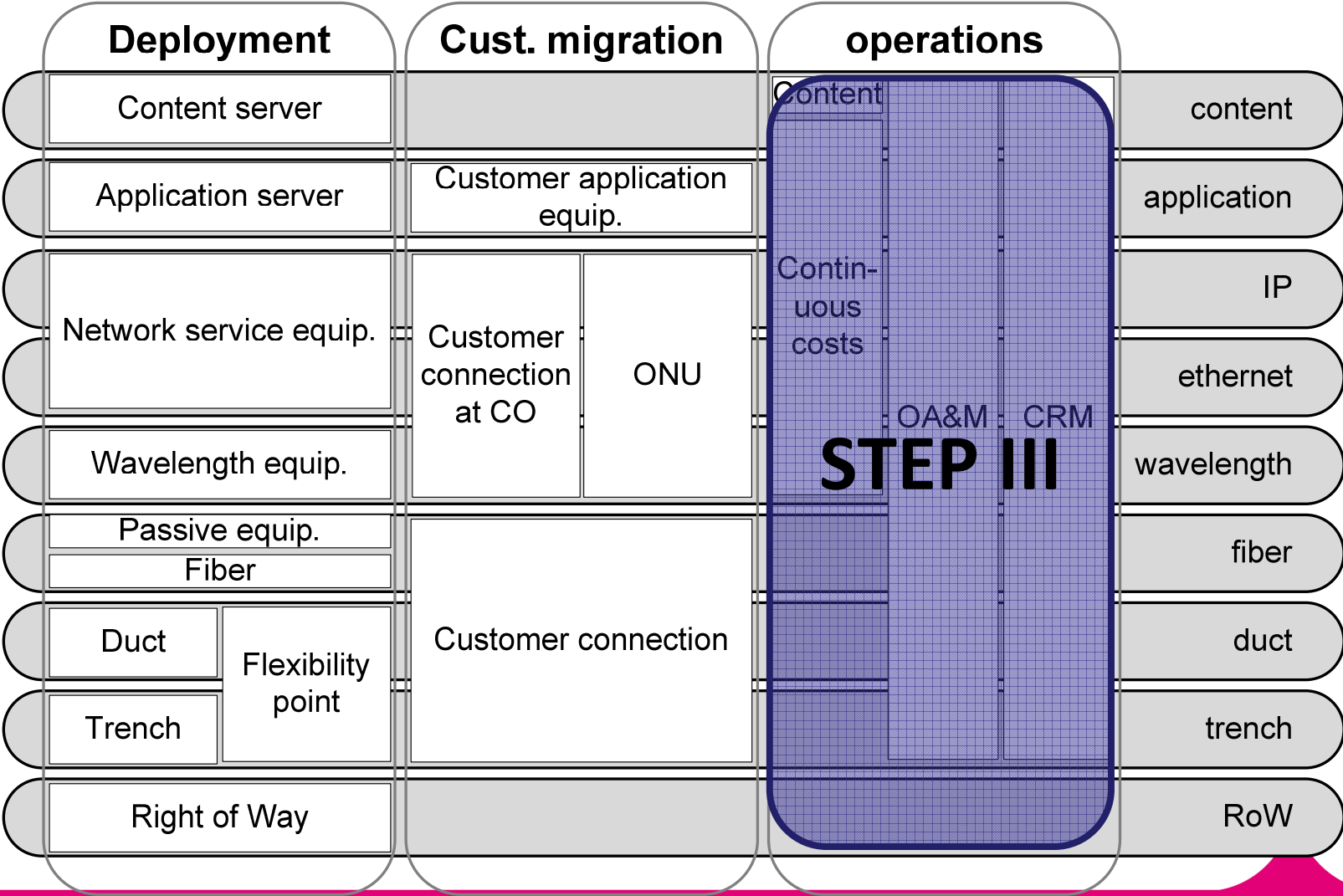

# Operating the Infrastructures Independently

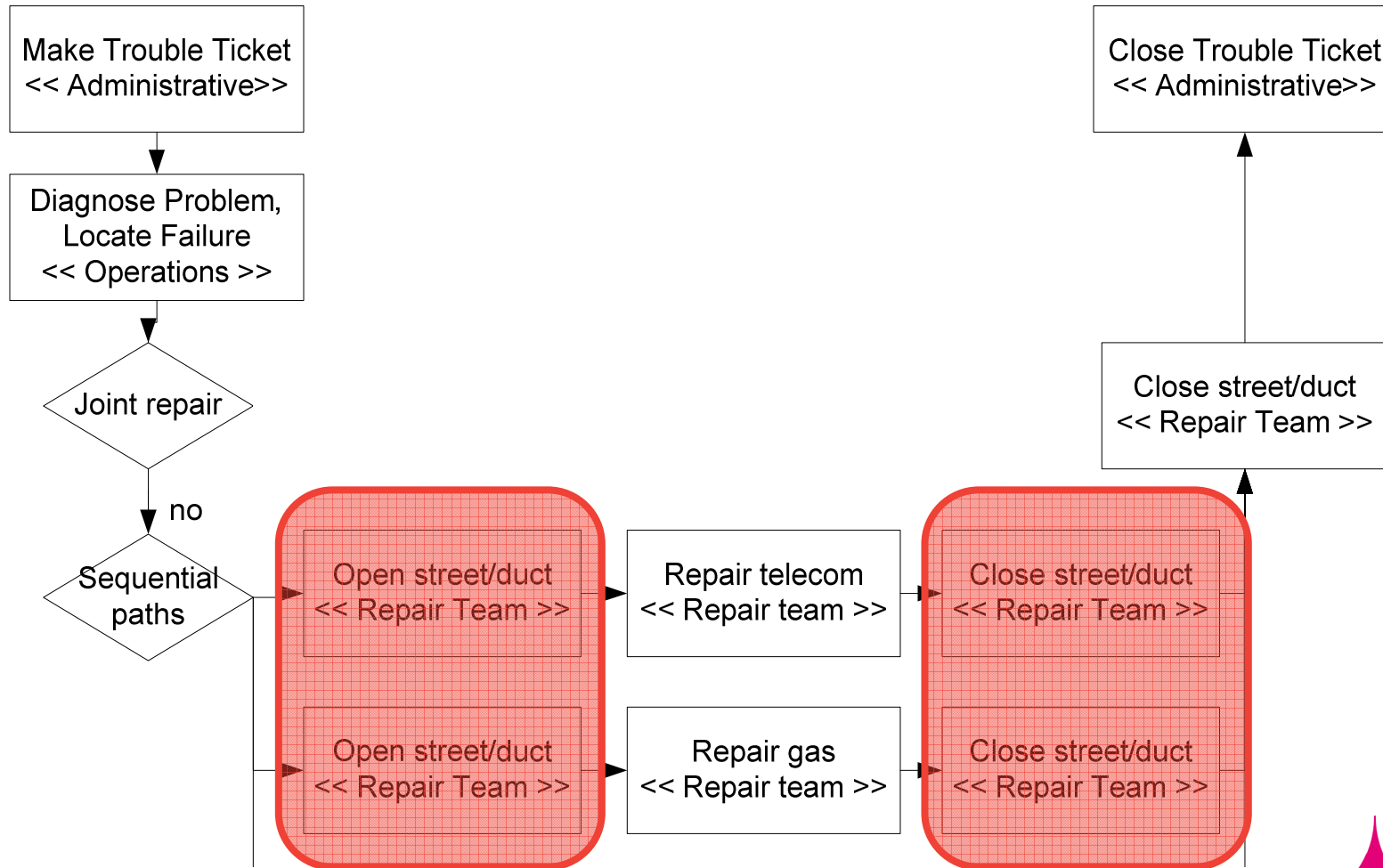

# Operating the Infrastructures Jointly

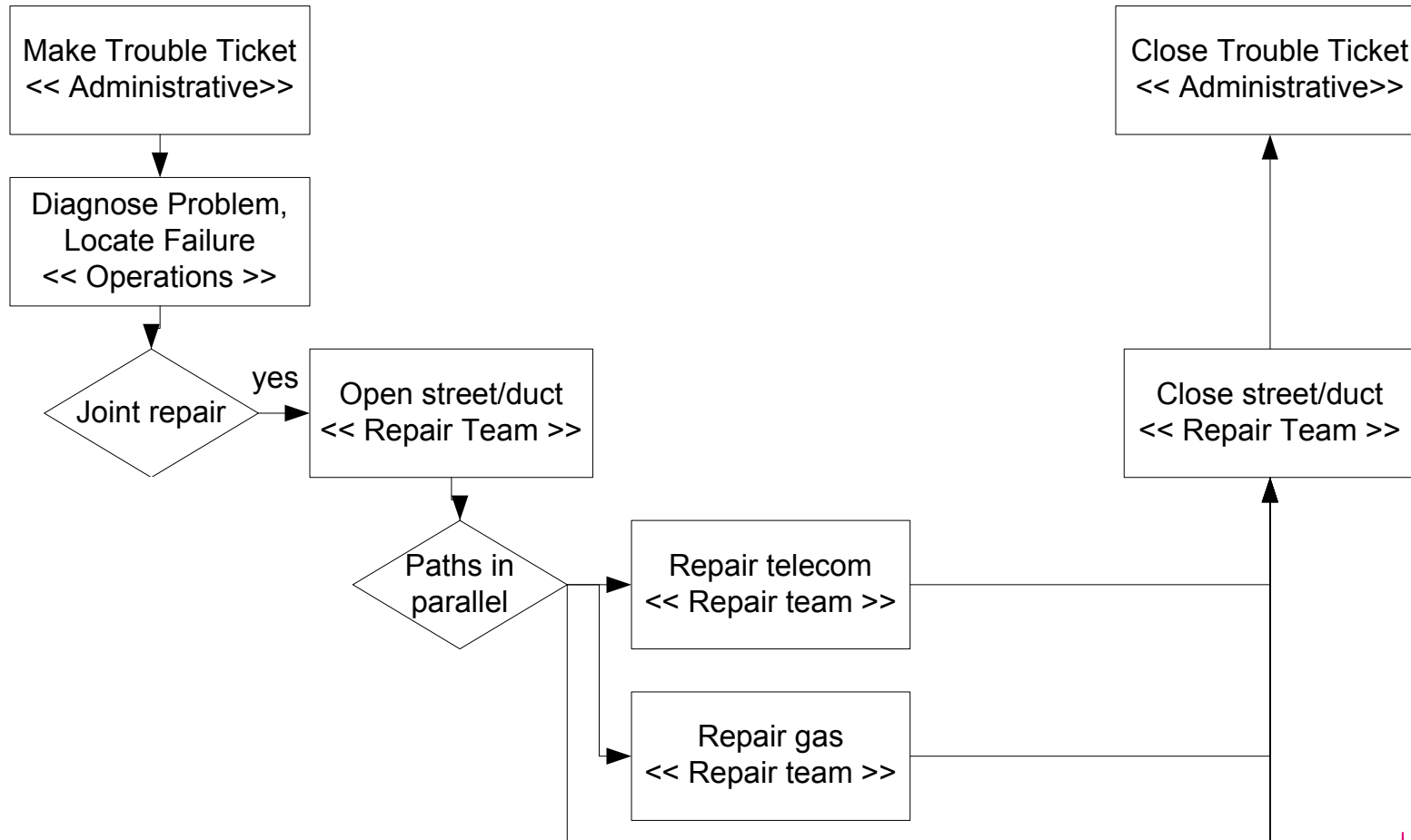

# Operate Joint Infrastructures Jointly

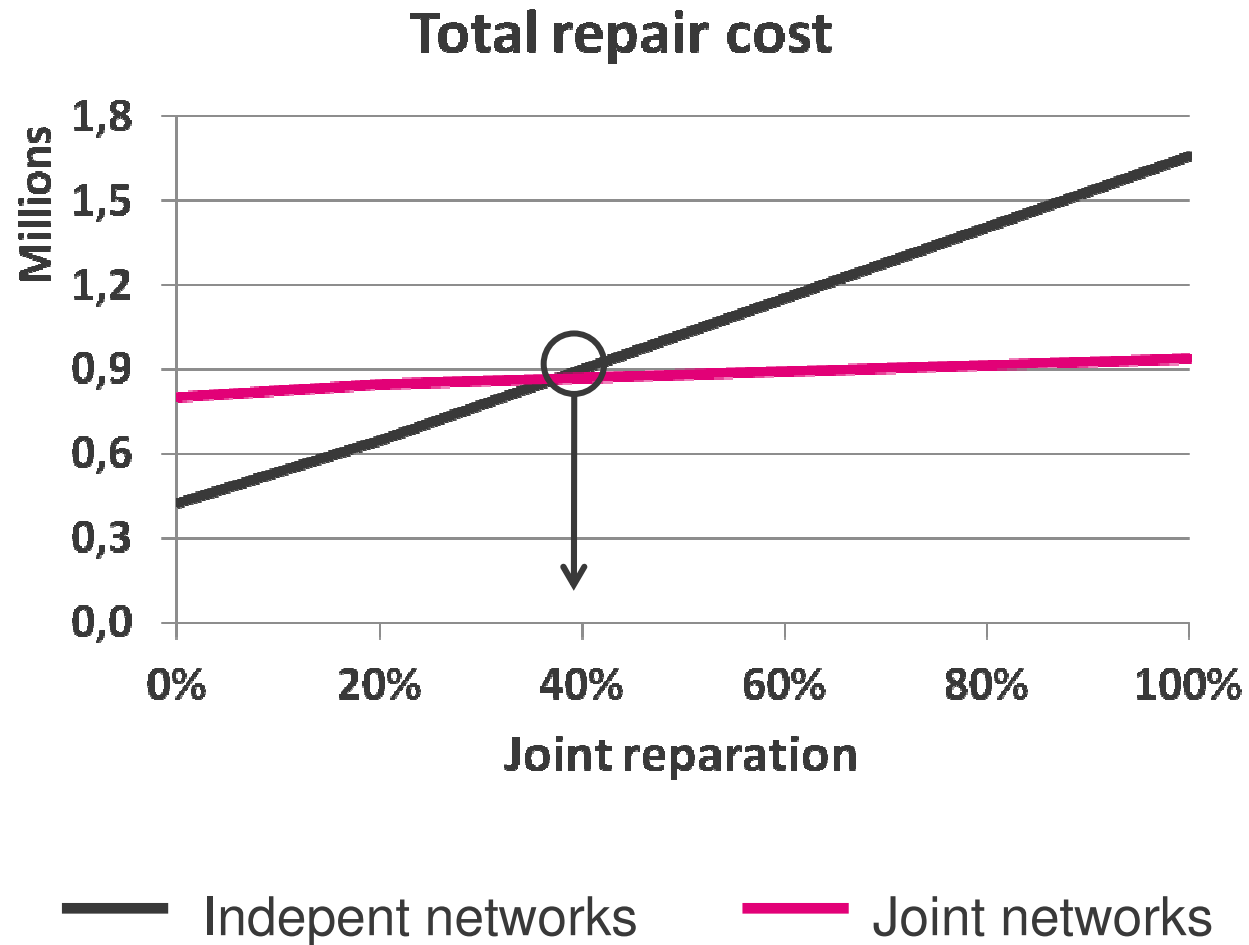

# A Call for Action



# A Call for Action

- **Geomarketing**
  - Public Geographical Information
  - Data Integrators
- **Joint Installation**
  - Incentives From Public Authorities
  - Legislative Frame
- **Joint Operations**
  - Operator Knowledge Bases
  - Vendor-Operator Cooperation

# Holistic Approach

Higher coverage

Lower price

Faster Deployment



*Thanks for the Attention..  
Any Questions?*



Bart Lannoo  
[bart.lannoo@intec.ugent.be](mailto:bart.lannoo@intec.ugent.be)  
Tel.: (+32) 9 33 14998