

A Comparative Model and Techno-Economic Analysis of Next
Generation AON Ethernet and TDM PON

*ACREO AB, Sweden, **Kun Wang**, Claus Popp Larsen, Anders Gavler, Mikhail Popov
IBBT, Belgium, Bart Lannoo,
Alcatel-Lucent, Bell lab France, Dominique Chiaroni*

Contact: kun.wang@acreo.se

Outline

- Network topology overview
- Comparison of four different architectures
- CAPEX comparison of 10G TDM PON and 1G AON
 - Assumptions and cost compositions
 - Network element
 - Dimensioning
- Summary

Network Topology overview

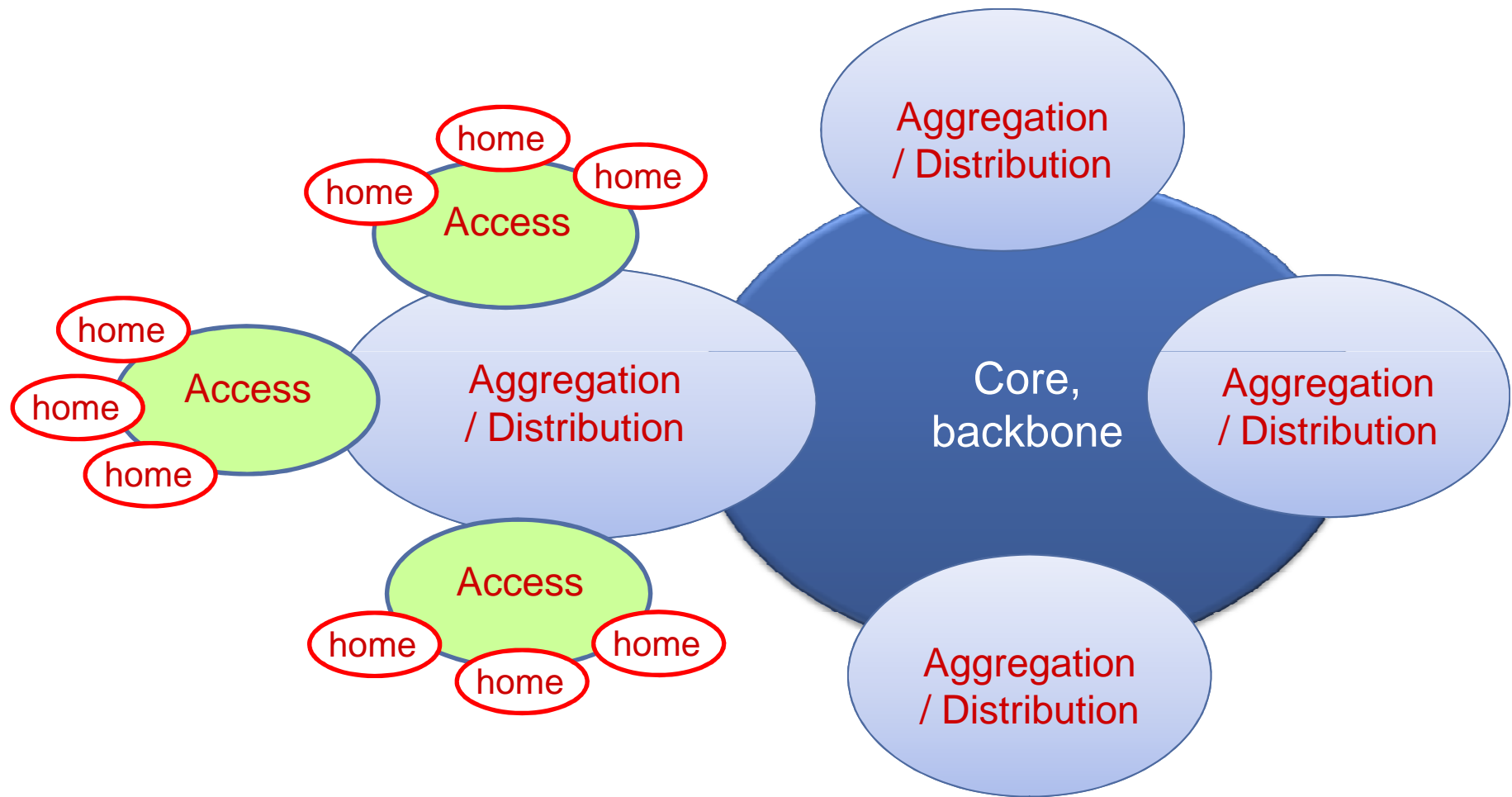

FTTx comparative model

- Equipment, topology, architecture

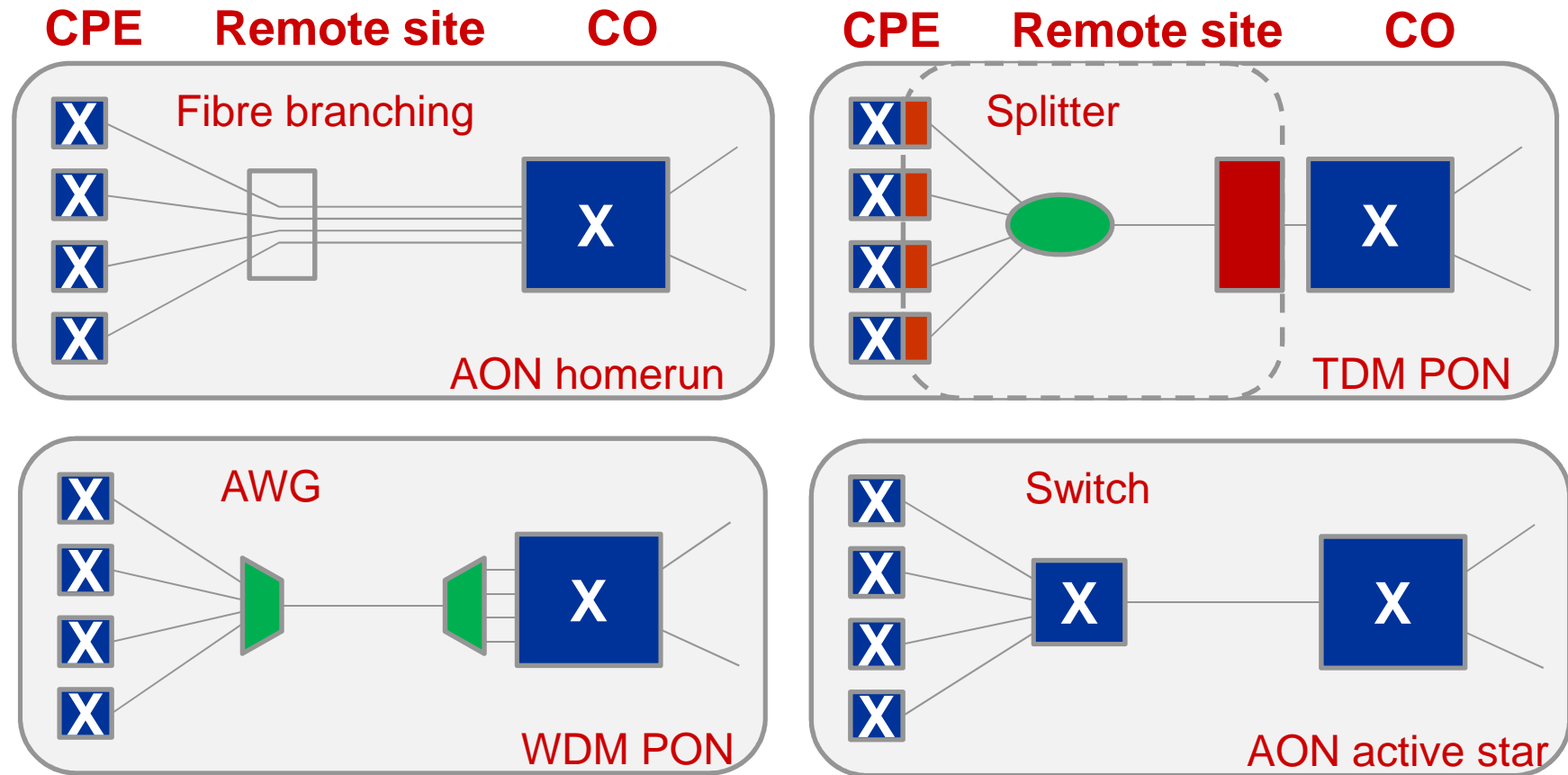

Ethernet equipment

TDM equipment

Optical equipment

Cost comparison 1G AON vs 10G TDM PON

- Assumptions

- Sustainable bandwidth 312Mb/s
- Peak bandwidth 1Gb/s
- Number of subscriber
- End to End services
- No OPEX
- Green field
- PON 1 fiber solution, AON 2 fiber
- AON +10% costs @ civilwork, ducts, fiber installation (closer to end user, the less add-on cost)
- AON homerun (P2P), +30% costs (ONLY in FEEDER)
- Flexible node costs: AON homerun < PON < AON active star

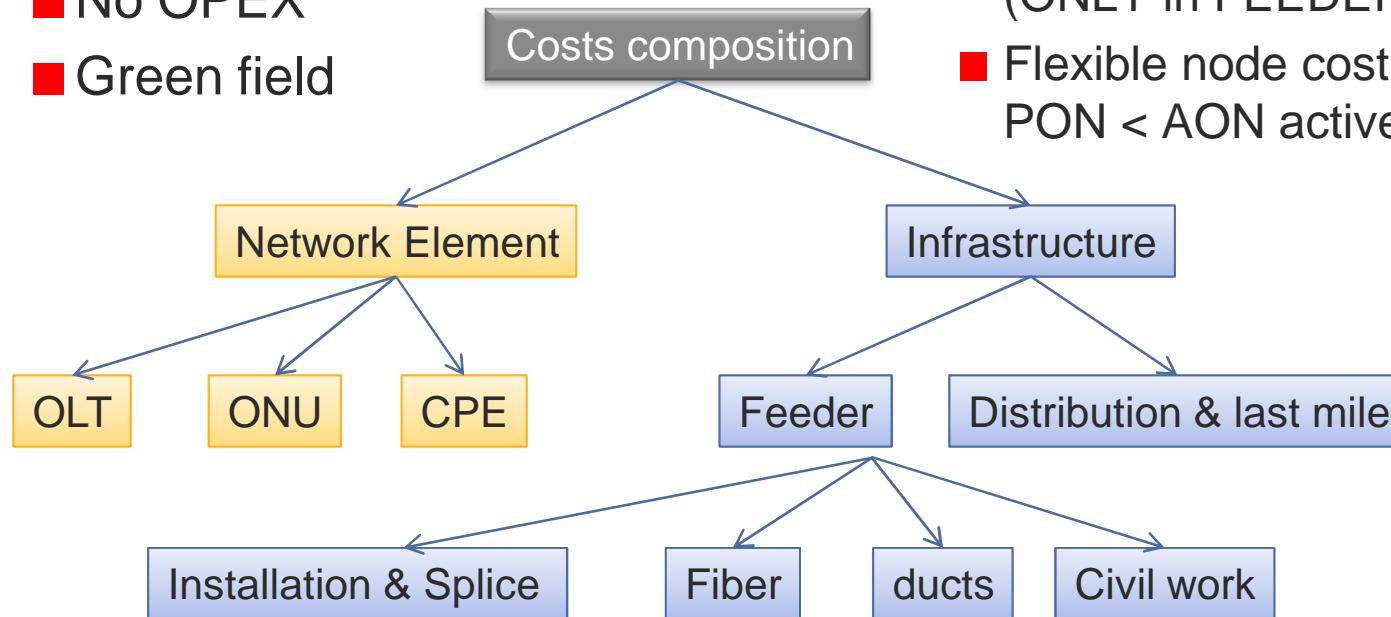

Network elements

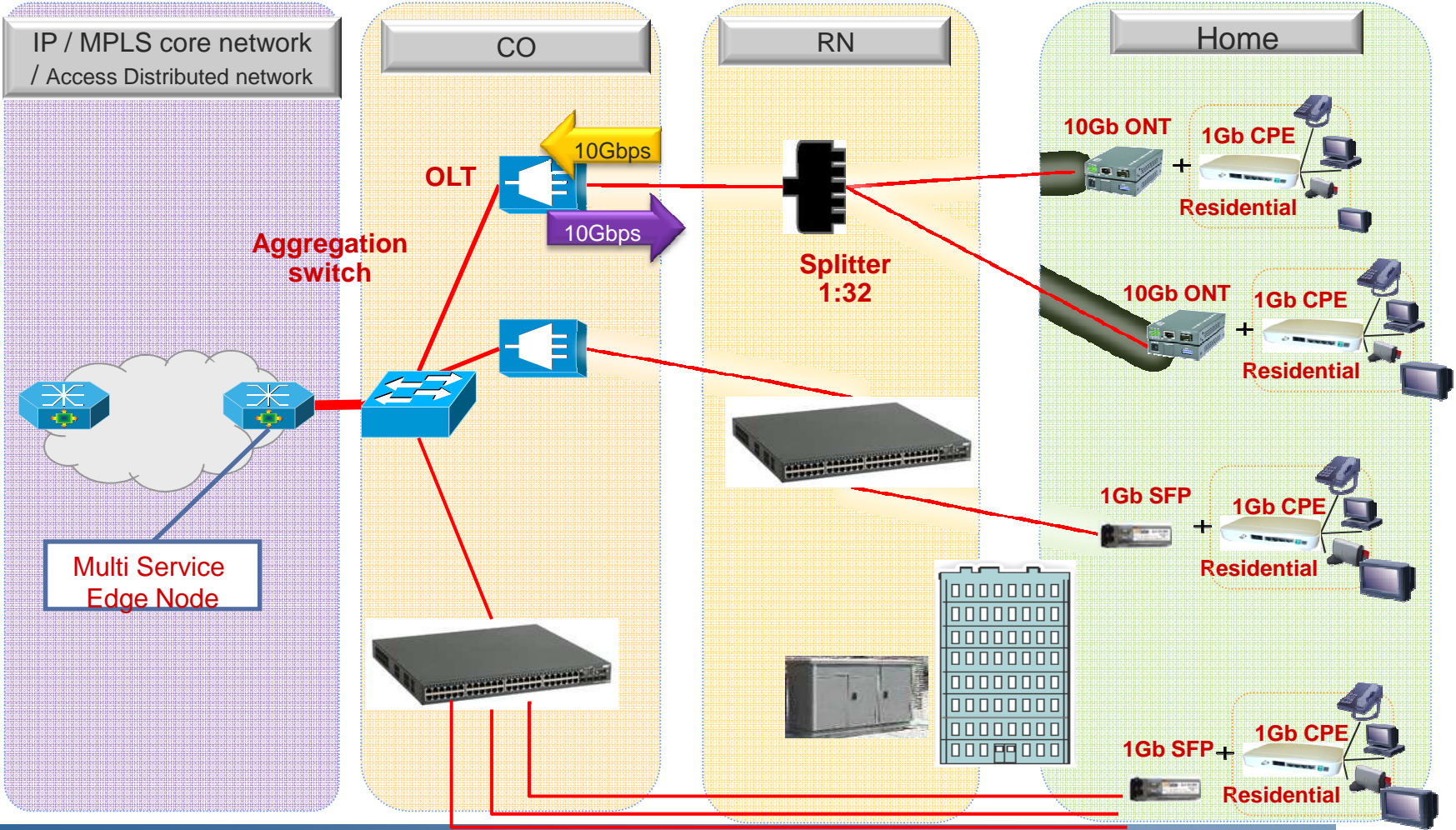

Dimensioning: Urban

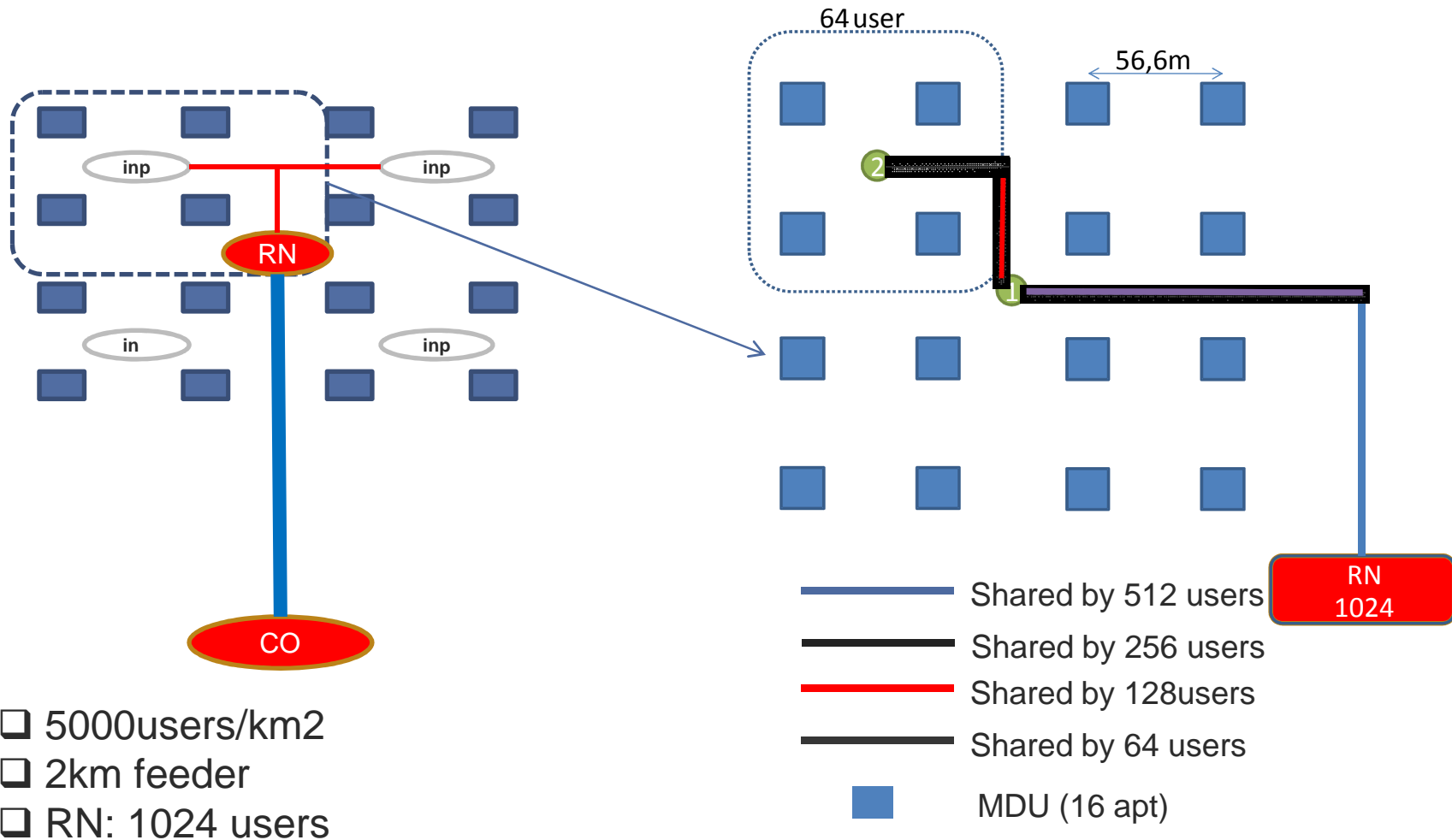

Dimensioning: Rural

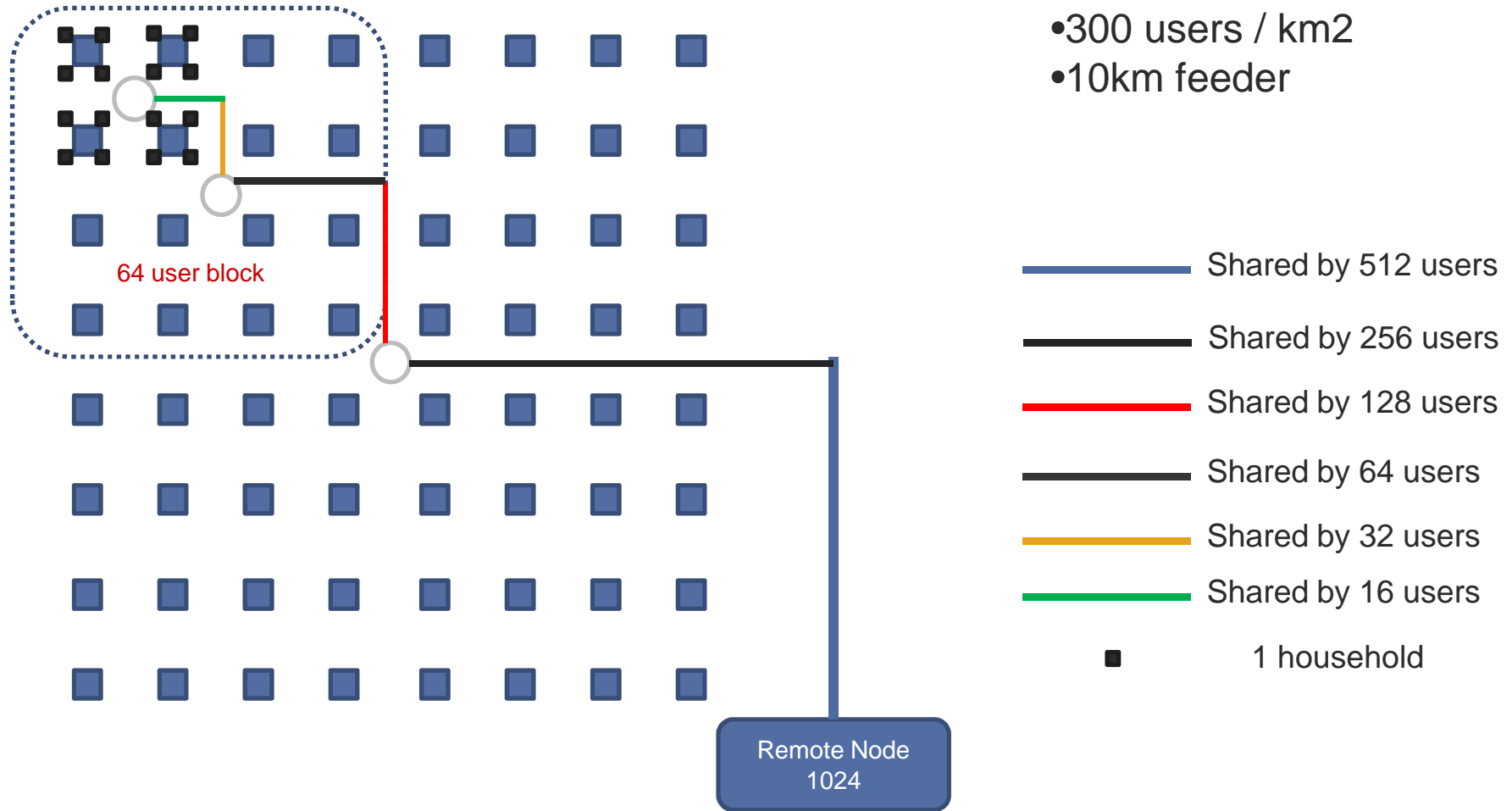

Cost comparison 1G AON vs 10G TDM PON

- 2010 and 2016

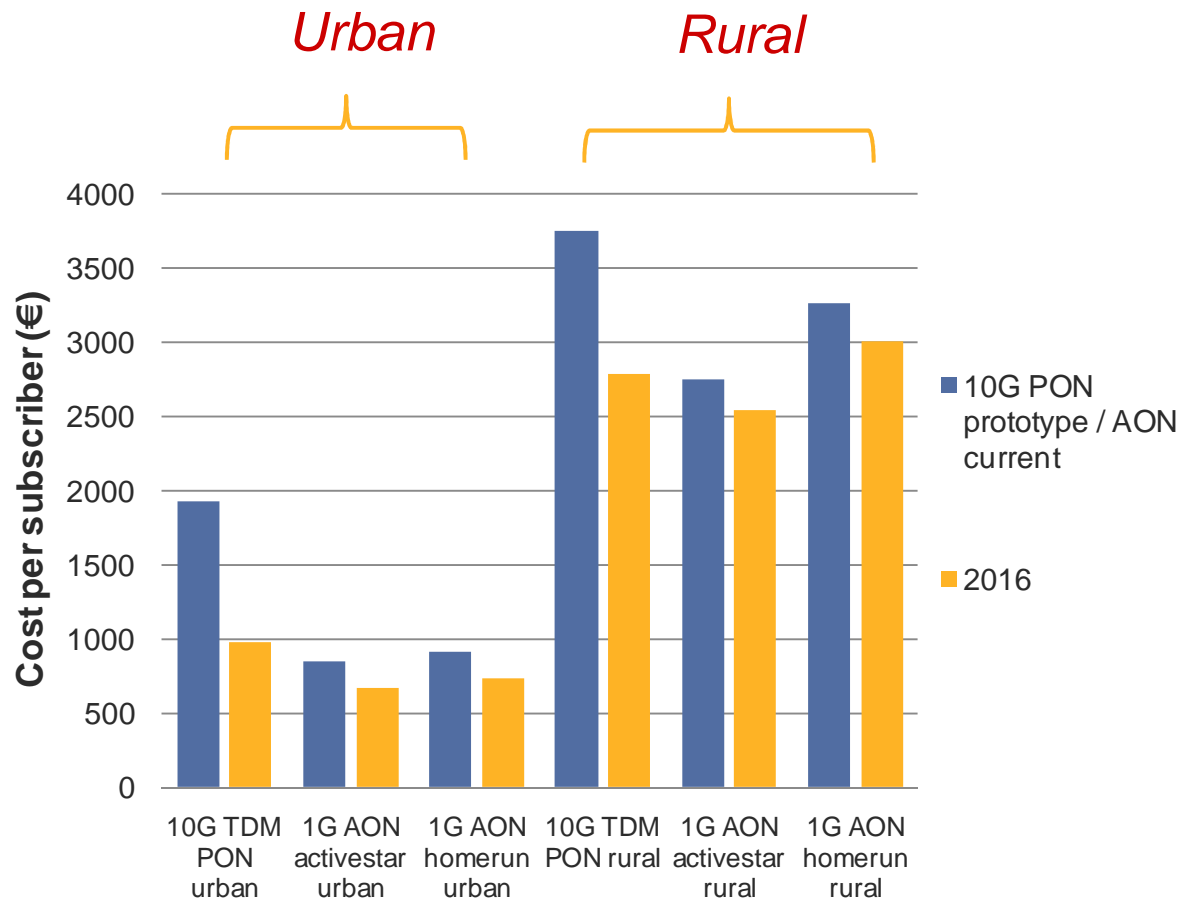

- 10GPON Prototype
- 10% *equipment* price reduction per 2 years
- No cost reduction on Civil work related part
- Urban
 - ▶ 5000 homes/km²
 - ▶ 2 km feeder fibre
- Rural
 - ▶ 300 homes/km²
 - ▶ 10 km feeder fibre

Cost comparison 1G AON vs 10G TDM PON

- cost composition

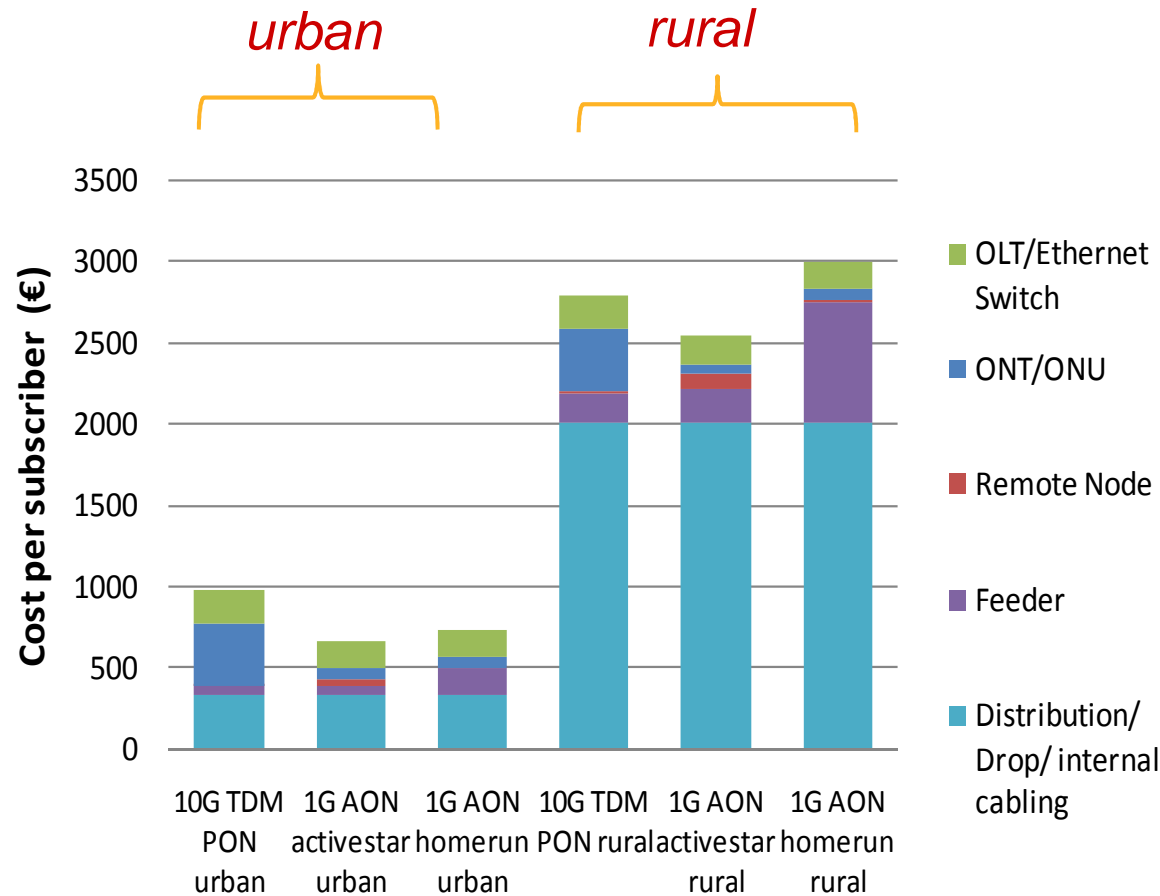

- 2016 estimates
- Fiber Infra. Major cost
- ONT cost is important
 - ▶ 10G optic+TDM syn
 - ▶ AON mature tech
- Urban
 - ▶ 5000 homes/km²
 - ▶ 2 km feeder fibre
- Rural
 - ▶ 300 homes/km²
 - ▶ 10 km feeder fibre

CONCLUSION

- ❑ Fiber infrastructure is major cost
- ❑ AON is cost effective in urban area
- ❑ 10G TDM PON is more competitive in rural area
- ❑ ONT cost for 10G PON is critical (10G transceiver & TDM sync)
- ❑ 10G PON have possibility to upgrade peak bandwidth to 10Gbps, (10Gbps capable Eth gateway needed)
- ❑ OPEX, business model, WDM PON etc may have higher impact on Tech.

Thanks!

