

# Flexible hybrid WDM/TDM PON: Architectures, MAC Protocols and Techno-Economic Evaluation

**Bart Lannoo, IBBT**

**Goutam Das, Abhishek Dixit, Didier Colle,  
Mario Pickavet, Piet Demeester**

ACP 2010, Shanghai, China, December 8-12, 2010



# Existing Optical Access

## Different Options of Deployment

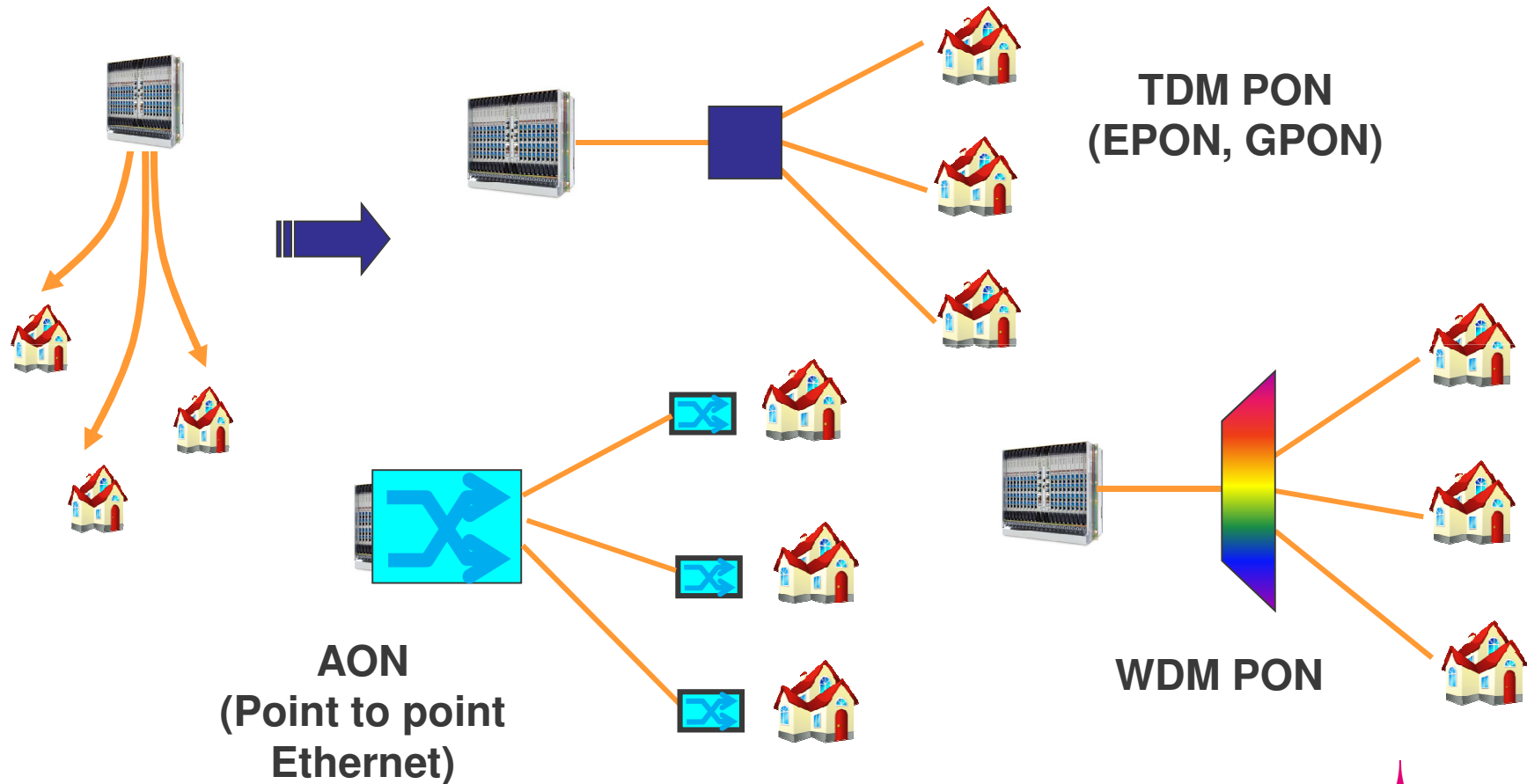

# NGOA requirements

- Subscriber per feeder fiber (fan-out) > 1000
- Long Reach: 60 – 100 km
- Higher data rate
  - Peak: 1Gbps per subscriber
  - Sustainable: 500 Mbps per subscriber

**None of the existing technologies meet the future demands!**

- **Moreover, flexibility becomes a key request!**

# Outline

- **Next-generation optical access (NGOA)**
- Hybrid WDM/TDM PON architectures
- Need for flexibility
- MAC protocols
- Techno-economic evaluation
- Conclusions

# Next Generation Optical Access

## Capacity Upgrade, Higher Fan-out and Greater Reach

### 1. Fully passive (passive Hybrids of WDM TDM)

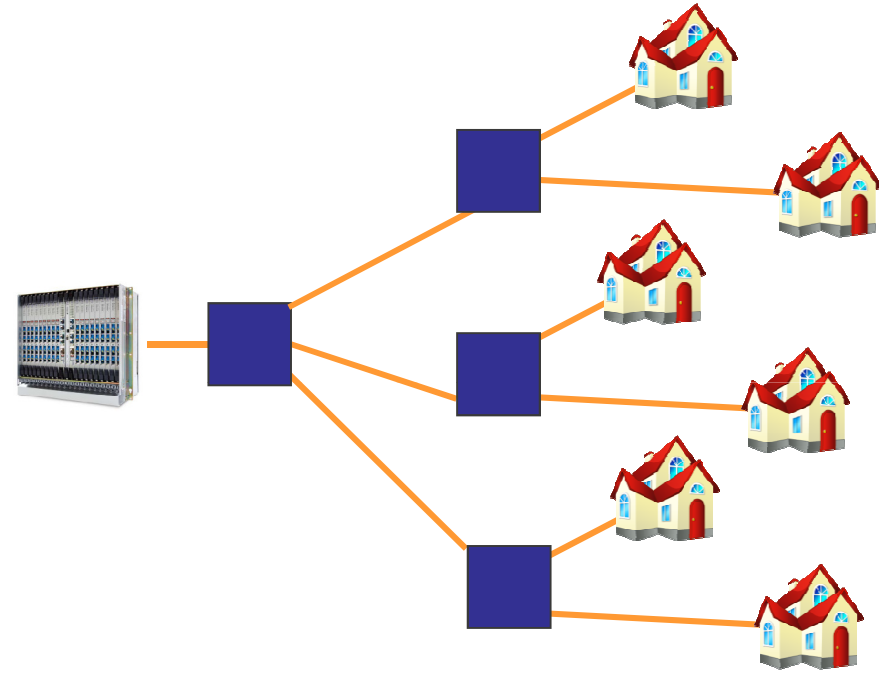
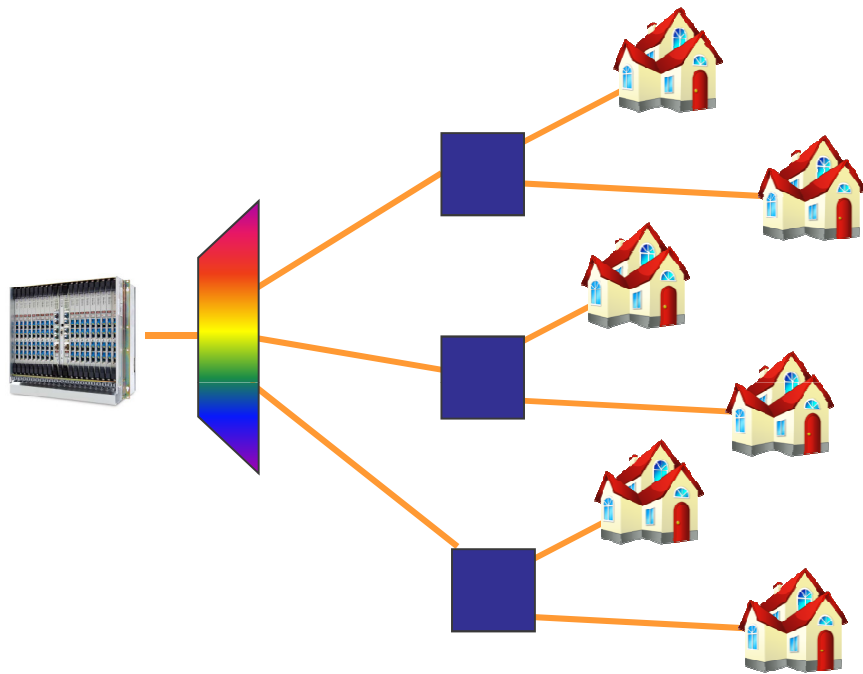

+	-
Power budget / Reach / Fan-out	No flexibility
Fully passive / Cost	

+	-
High flexibility	Power budget / Reach / Fan-out
Fully passive / Cost	
Simplicity	

# Next Generation Optical Access

## Capacity Upgrade, Higher Fan-out and Greater Reach

### 2. Semi passive (active switching in the remote node)

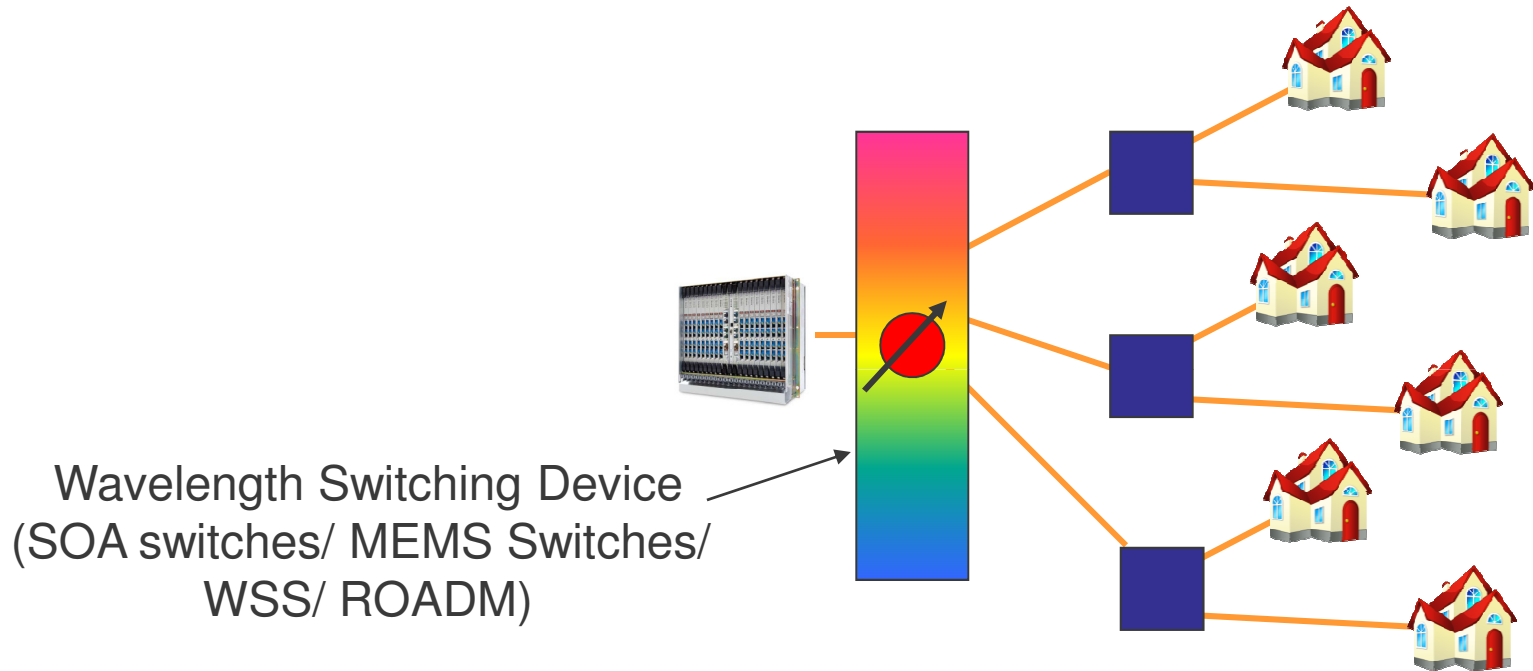

+	-
Power budget / Reach / Fan-out	Active components in the remote node
Fully flexible (higher statistical multiplexing gain)	Cost

# Next Generation Optical Access

## Capacity Upgrade, Higher Fan-out and Greater Reach

### 3. Active (OEO conversion in the network)

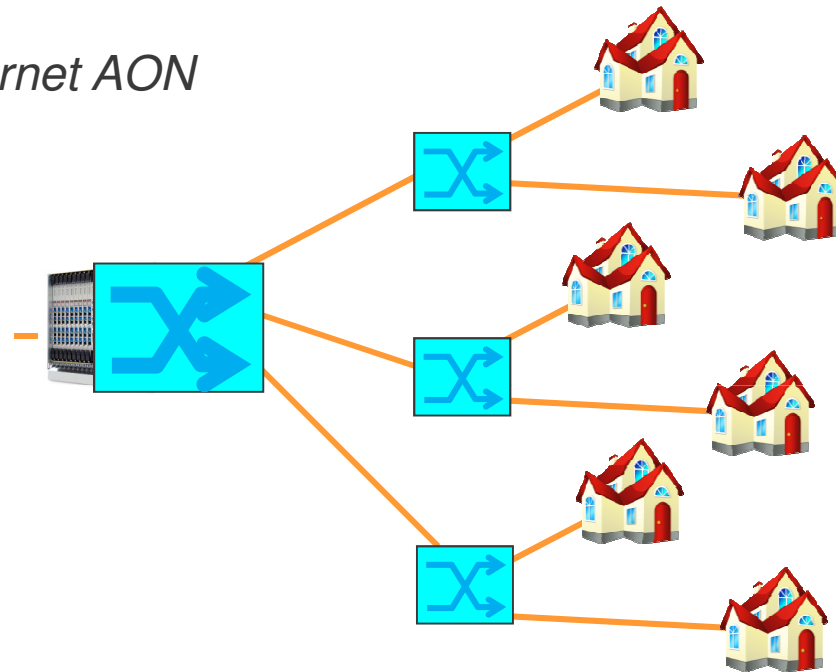

*E.g. Ethernet AON*



+	-
High flexibility (stat. multiplexing)	OEO conversion at remote node
Low Tx at user side	Operational cost
Power budget	

# NGOA network classifications

## Hybrid WDM/TDM PON

- **Fully passive** 
  - data and control remain optically transparent
    - only passive components in the access network, such as passive power splitters or arrayed waveguide gratings (AWGs)
- **Semi passive** 
  - data remains optically transparent
  - control needs OEO conversion
    - active optical components in the access network, e.g. optical switches, that need power and electronic control
- **Active** 
  - data and control need OEO conversion
    - electronic switches are installed in the network

*(C.P. Larsen et al. (Acreo), ACP 2010, paper FQ1, Shanghai, China, Dec. 2010)*

# Outline

- Next-generation optical access (NGOA)
- **Hybrid WDM/TDM PON architectures**
- Need for flexibility
- MAC protocols
- Techno-economic evaluation
- Conclusions

# Hybrid WDM/TDM PON building blocks

Central office  
**OLT**

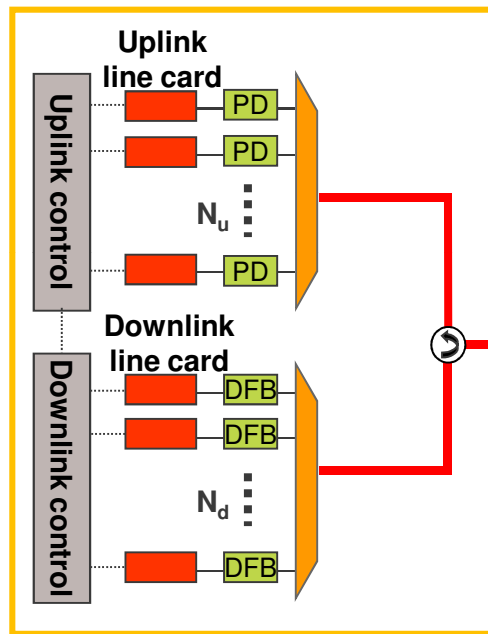

RN1  
Power splitter,  
wavelength splitter  
or optical switch

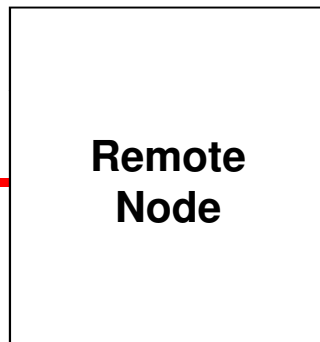

RN2  
Power splitter

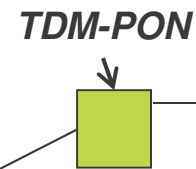

User  
**ONU**

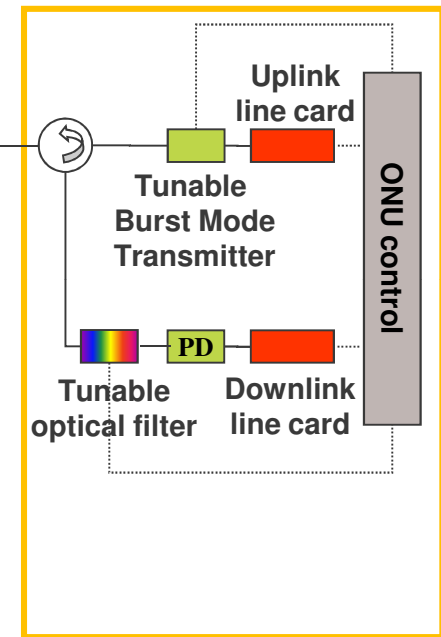

# Hybrid WDM/TDM PON

RN 1: wavelength broadcast & select PON (WBS-PON)

Central office  
**OLT**

RN1  
**Power splitter**

RN2  
**Power splitter**

User  
**ONU**

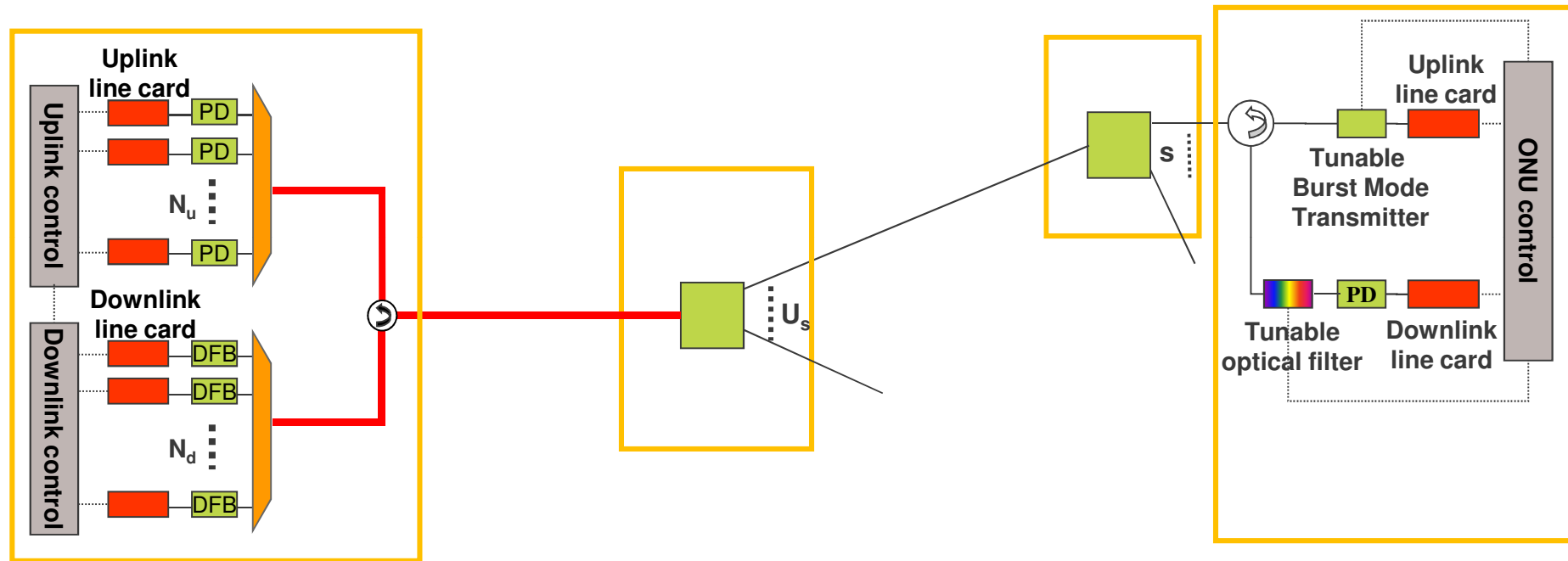

(V. Distelrath (NSN), ACP 2010, plenary session I.1, Shanghai, China, Dec. 2010)

	+	-
Simplicity		Power loss
Flexibility		Security

# Hybrid WDM/TDM PON

## RN 2: wavelength split PON (WS-PON)

Central office  
**OLT**

RN1  
**Wavelength splitter**

RN2  
**Power splitter**

User  
**ONU**

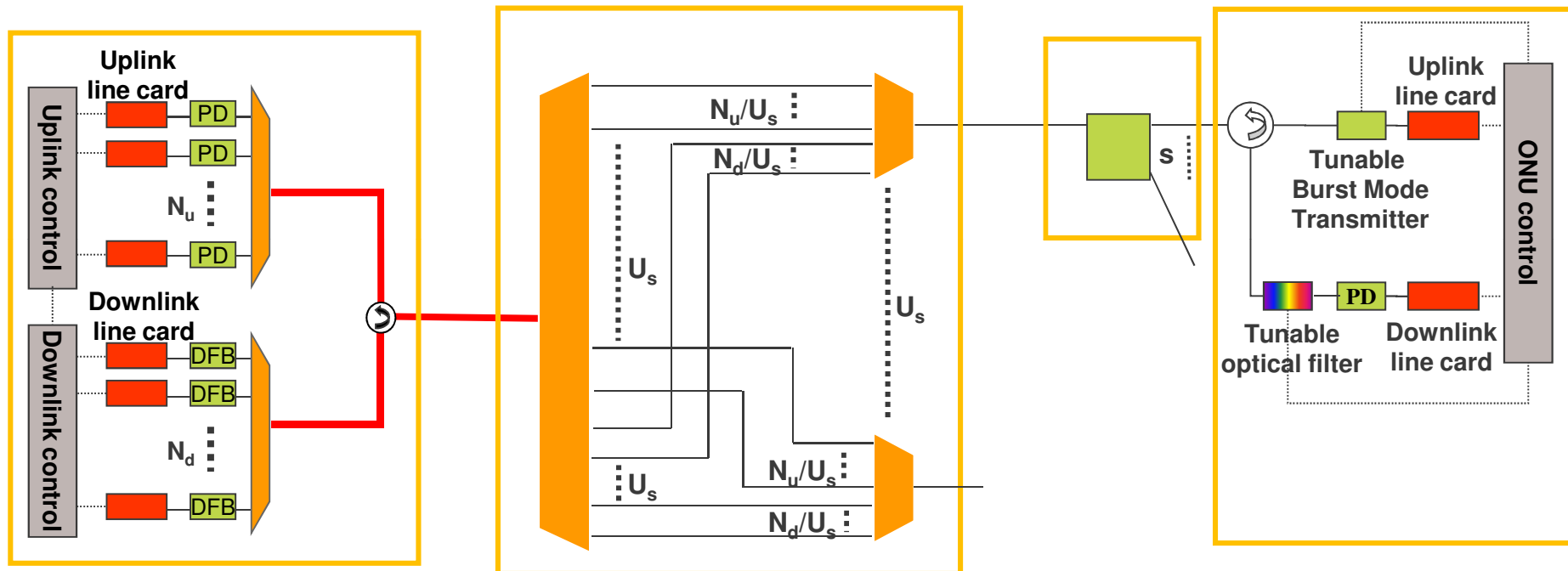

+	-
Power loss	Simplicity
Security	Flexibility

# Hybrid WDM/TDM PON

## RN 3: wavelength routed PON (WR-PON)

Central office  
**OLT**

RN1  
**Optical switch**

RN2  
**Power splitter**

User  
**ONU**

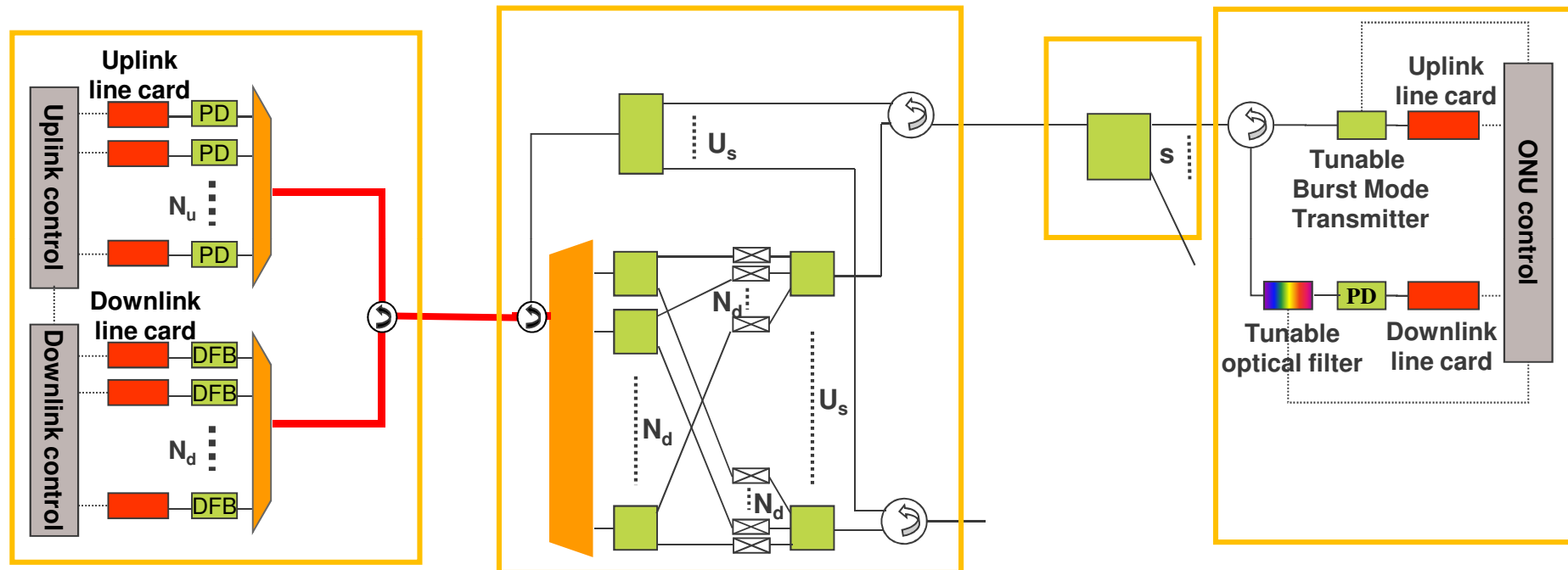

(N.C. Tran, et al. (TU/e), Future Network & Mobile Summit 2010, Firenze, Italy, June 2010)

+	-
Flexibility	Simplicity
Security	Power loss

# Hybrid WDM/TDM PON

## RN 4: wavelength selective switched PON (WSS-PON)

Central office  
**OLT**

RN1  
**Optical switch**

RN2  
**Power splitter**

User  
**ONU**

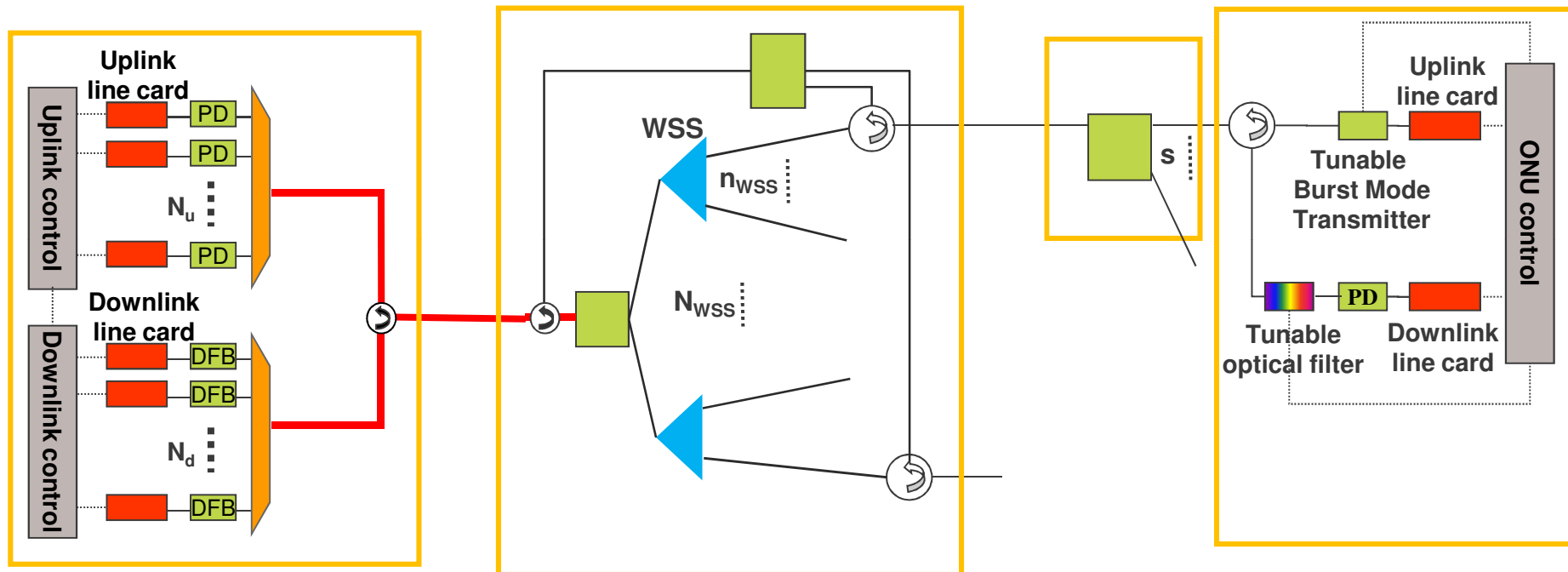

(G. Das, et al. (IBBT), ANTS 2010, Mumbai, India, December 2010)

+	-
Power loss	Simplicity
Security	Flexibility (partial)

# Hybrid WDM/TDM PON

## Remote node overview

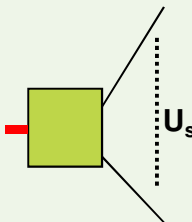
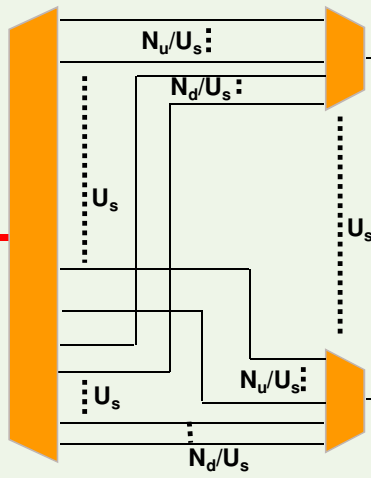
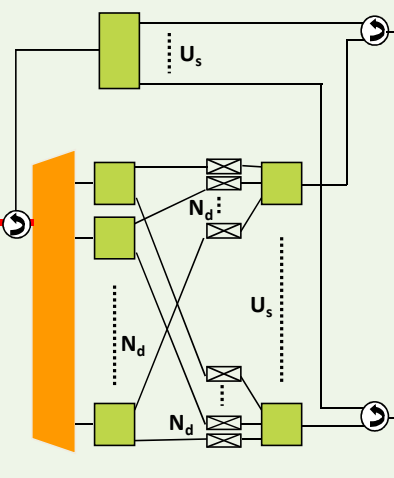
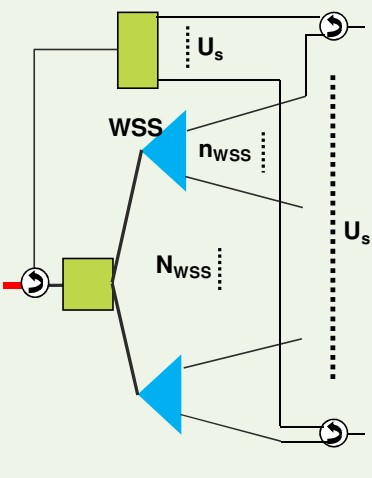
	1. Fully passive		2. Semi Active	
	RN1: WBS-PON	RN2: WS-PON	RN3: WR-PON	RN4: WSS-PON
				
Simplicity	Simple	Little complex	Complex	Complex
Flexibility	Full	No	Full	Partial
Power loss	High	Low	High	Low
Security	Low	High	High	High

# Outline

- Next-generation optical access (NGOA)
- Hybrid WDM/TDM PON architectures
- **Need for flexibility**
- MAC protocols
- Techno-economic evaluation
- Conclusions

# Need for flexibility? (1)

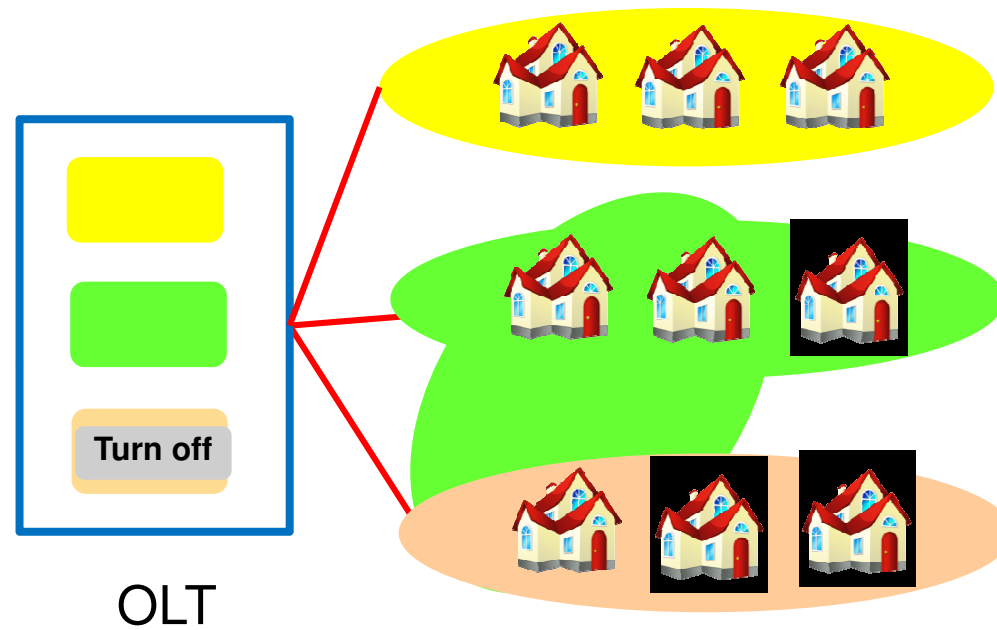

1. Better bandwidth utilization, leading to **energy savings**

## Need for flexibility? (2)

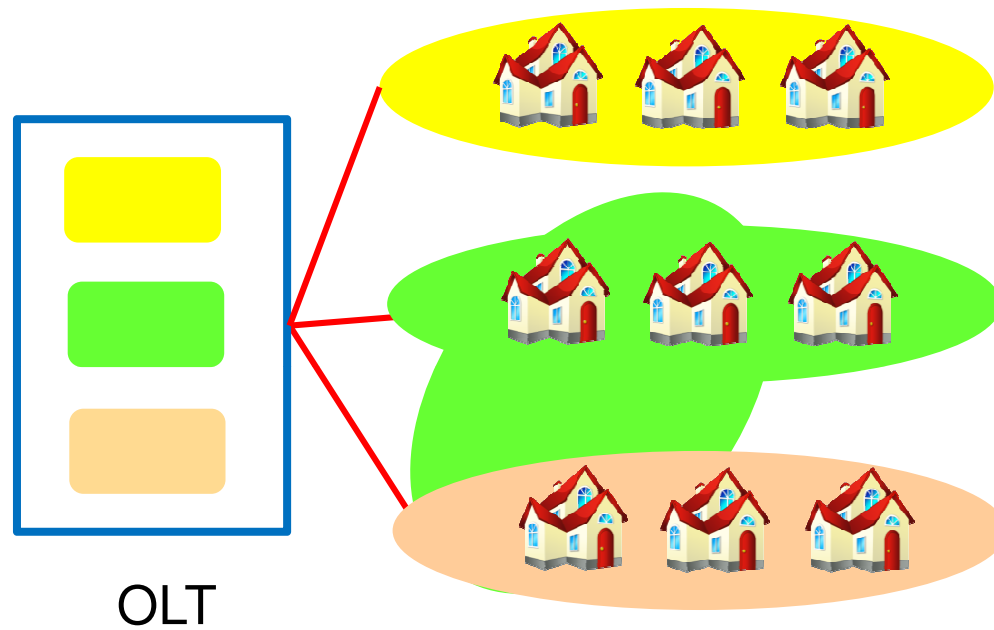

## 2. Easier network upgrades and extensions

# Need for flexibility? (3)

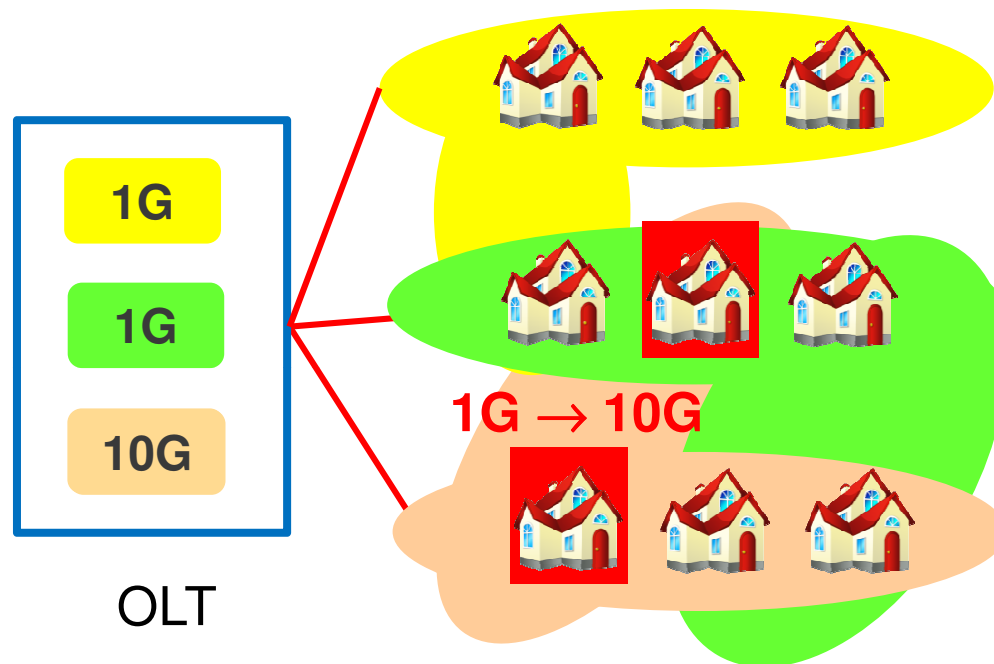

## 3. Easier network evolution and migration

# Outline

- Next-generation optical access (NGOA)
- Hybrid WDM/TDM PON architectures
- Need for flexibility
- **MAC protocols**
- Techno-economic evaluation
- Conclusions

# Passive Optical Network (PON)

OLT

splitter

ONU

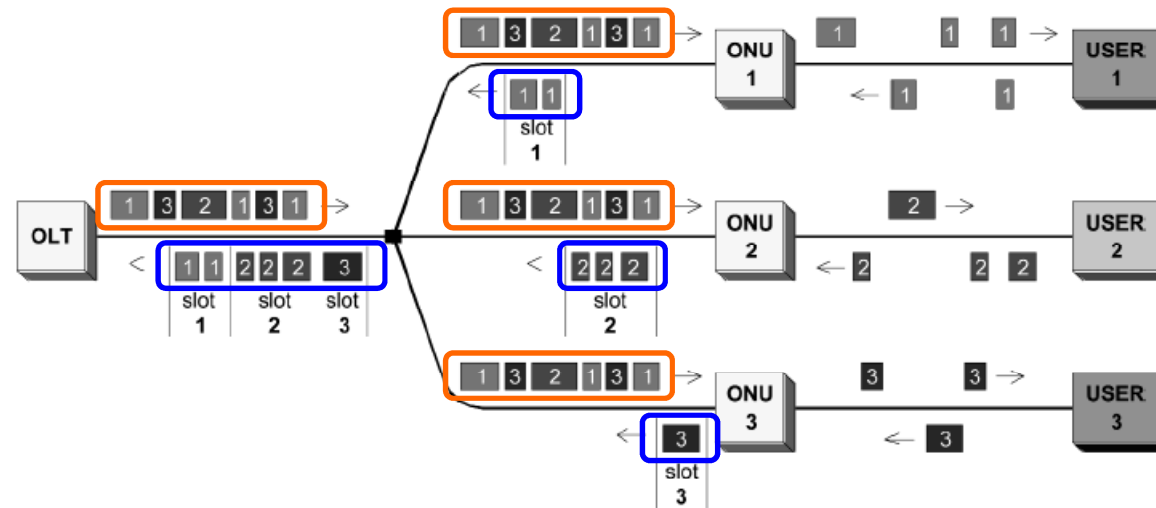

- **Downstream (P2MP):**
  - TDM-PON: passive splitter  $\Rightarrow$  packets filtered in ONUs
  - WDM-PON: wavelength splitter, e.g. AWG
  - Hybrid WDM/TDM PON: passive splitters, wavelength splitters, optical switches
- **Upstream (MP2P):**
  - MAC protocol to avoid collisions (e.g. MPCP in EPON)
  - Dynamic bandwidth allocation (DBA) algorithm (e.g. IPACT)

# Approaches for WDM on top of TDM

- **Separate** Time and Wavelength Assignment  
(simple but not efficient approach)
- **Joint** Time and Wavelength Assignment  
(for network extensibility and energy efficiency)
  - **Online** approaches
    - First Available **Wavelength** (FAW) approaches  
Earliest Finish Time (EFT) and Latest Finish Time (LFT)
    - First Available **Void** (FAV) approaches  
EFT and LFT (efficient but very complex to implement)
  - **Offline** approaches
    - More fair and less complex but can not compete in terms of high efficiency and low delays of online approaches

Example for sleep mode

# Dynamic Bandwidth Allocation (DBA)

## Modified packet format

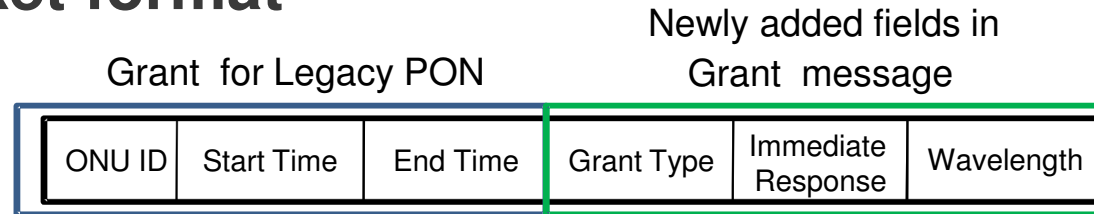

### New Grant message

- Every ONU has **dedicated downstream** wavelength (for recovery)
- OLT can **dynamically allocate another downstream** wavelength
  - Through "Control Header"
  - Control header processor unit
  - By configuring switches in RN1
- ONUs notified through "**Grant message**" about new wavelength
  - "Grant Type": set to downstream grant
  - "Wavelength": set to required wavelength
- Tunable PD adjusts to newly allocated downstream wavelength

# Offline scheduling - Sleep mode operation

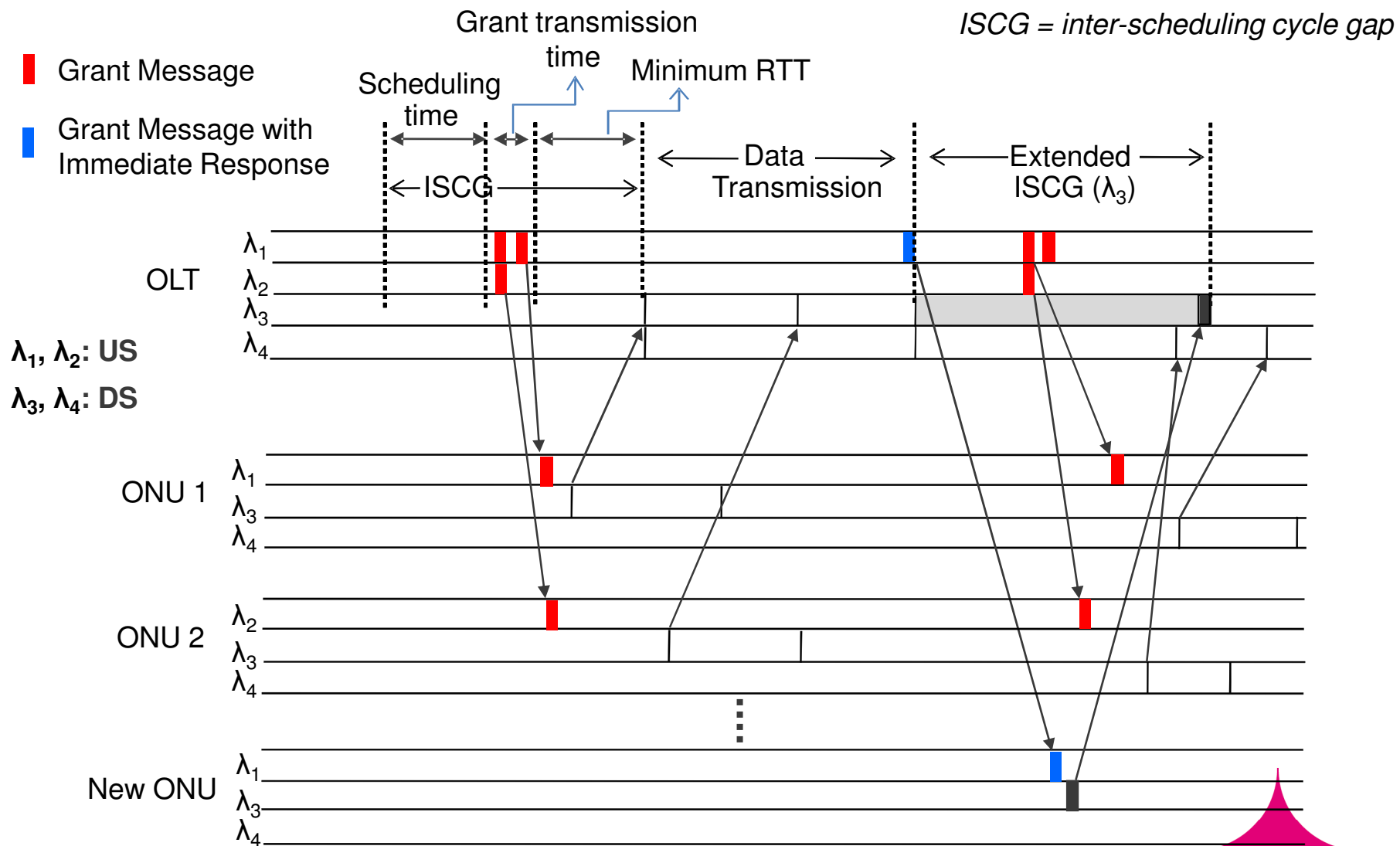

# Dynamic bandwidth allocation simulations

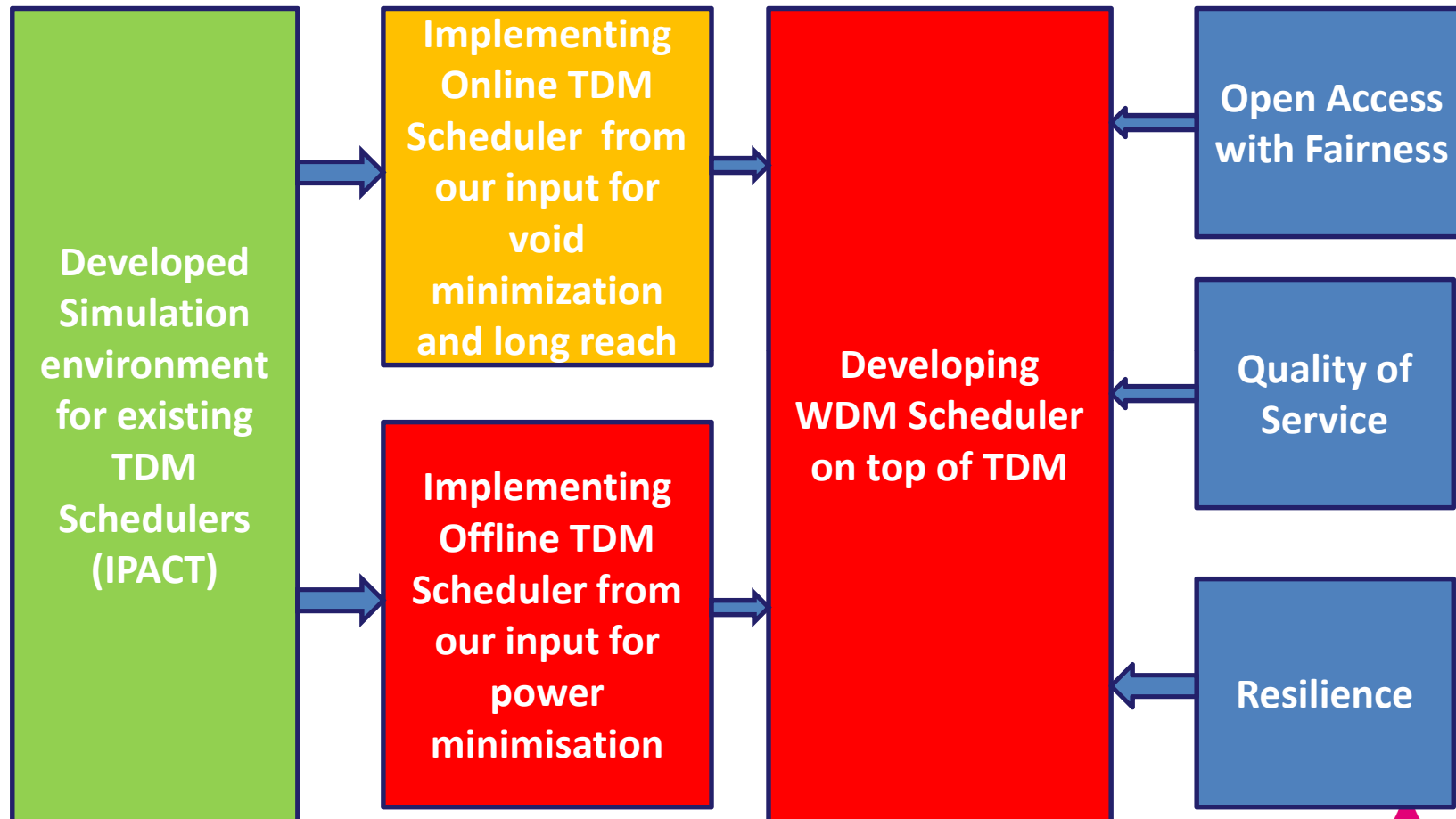

# Outline

- Next-generation optical access (NGOA)
- Hybrid WDM/TDM PON architectures
- Need for flexibility
- MAC protocols
- **Techno-economic evaluation**
- Conclusions

## Case: urban vs. rural

	Urban	Rural
Pop. density	5000 inh./km <sup>2</sup>	300 inh./km <sup>2</sup>
House types	MDU with 16 apartments	Single family houses
Min. feeder distance	2 km	10 km

# Hybrid WDM/TDM PON

benchmark scenario 1: no flexibility

Central office  
**OLT**

RN1  
**Wavelength splitter**

RN2  
**Power splitter**

User  
**ONU**

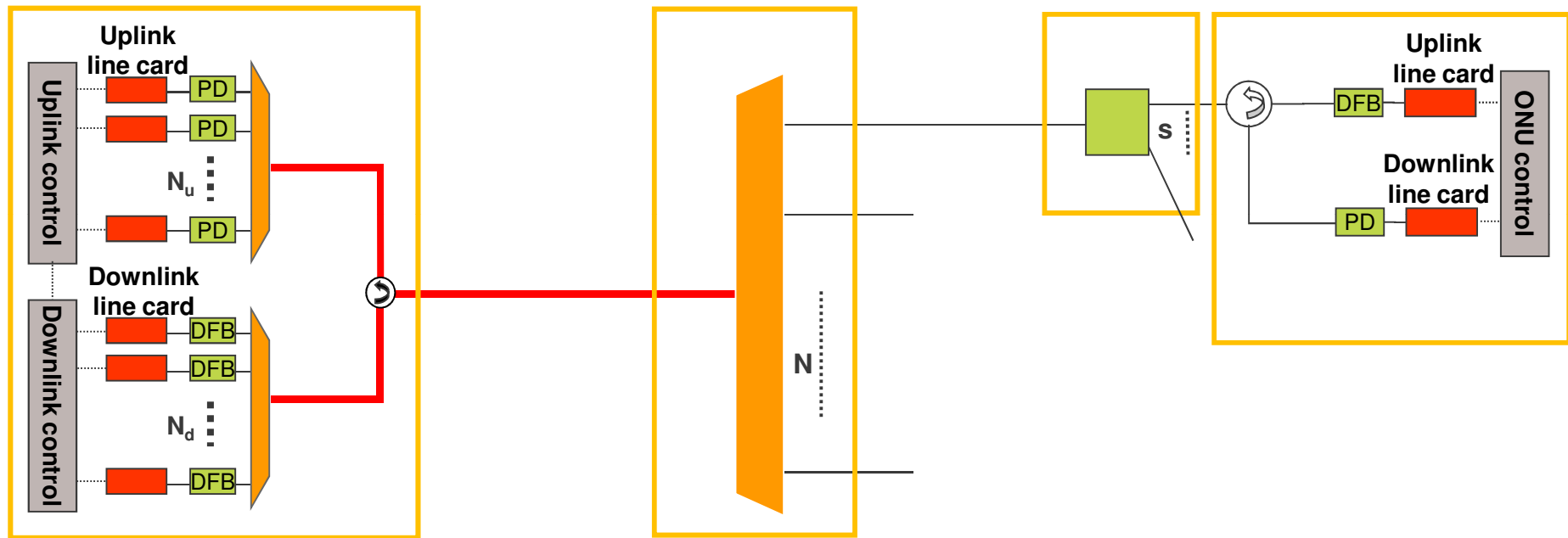

# Hybrid WDM/TDM PON

## benchmark scenario 2: full flexibility

Central office  
**OLT**

RN1  
**Wavelength splitter**

RN2  
**Power splitter**

User  
**ONU**

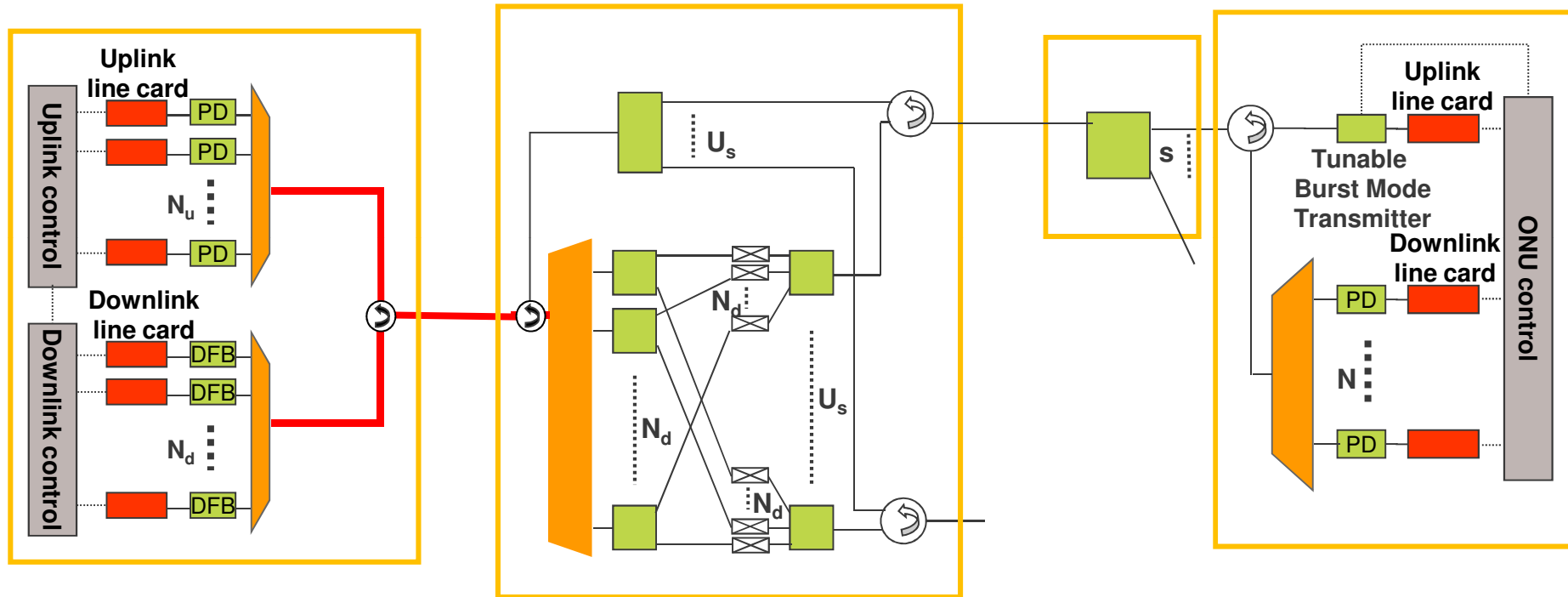

# Hybrid WDM/TDM PON technologies

## Cost breakdown (urban area) – cost/subscriber

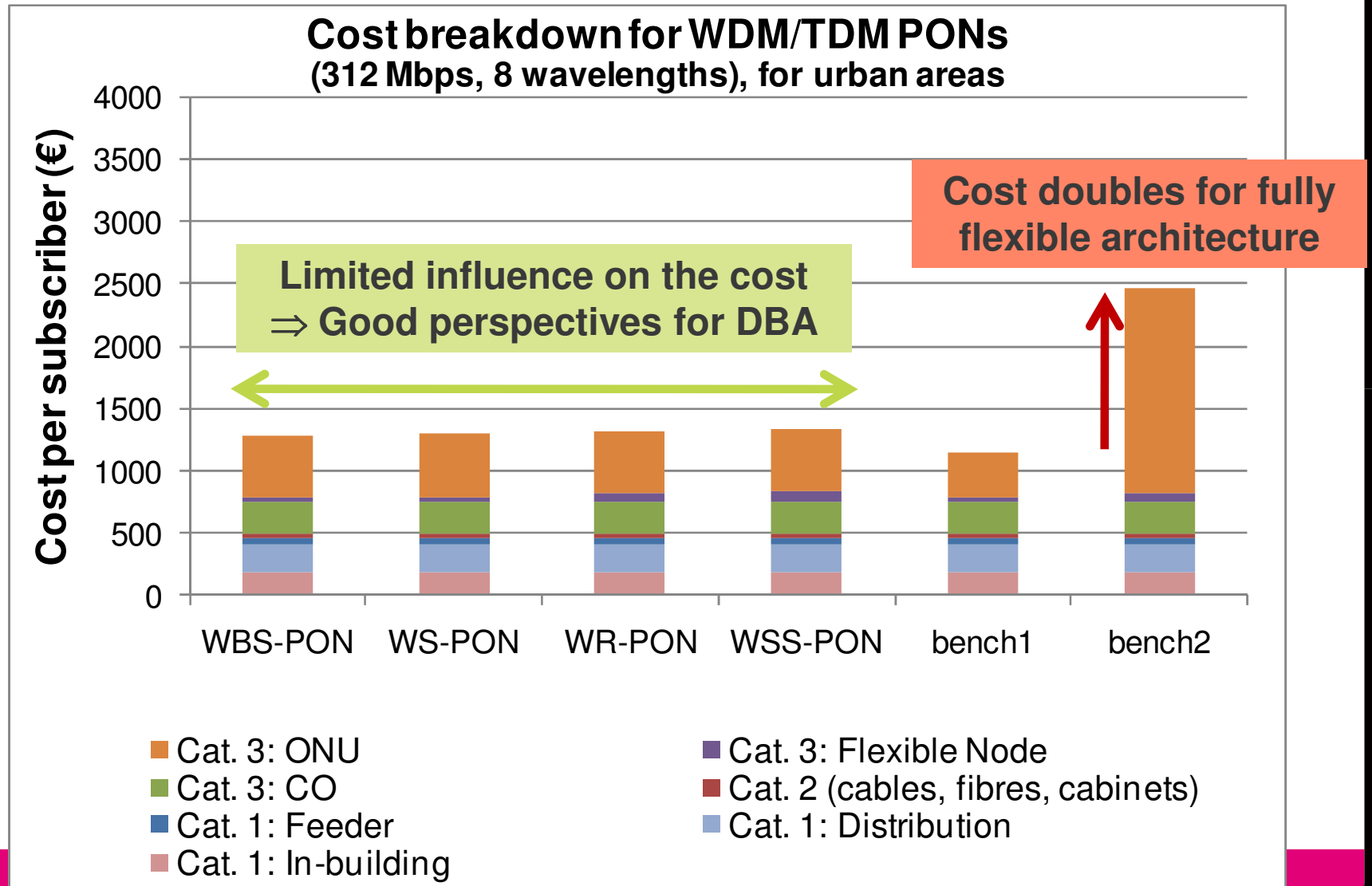

# Hybrid WDM/TDM PON technologies

Cost breakdown (rural area) – cost/subscriber

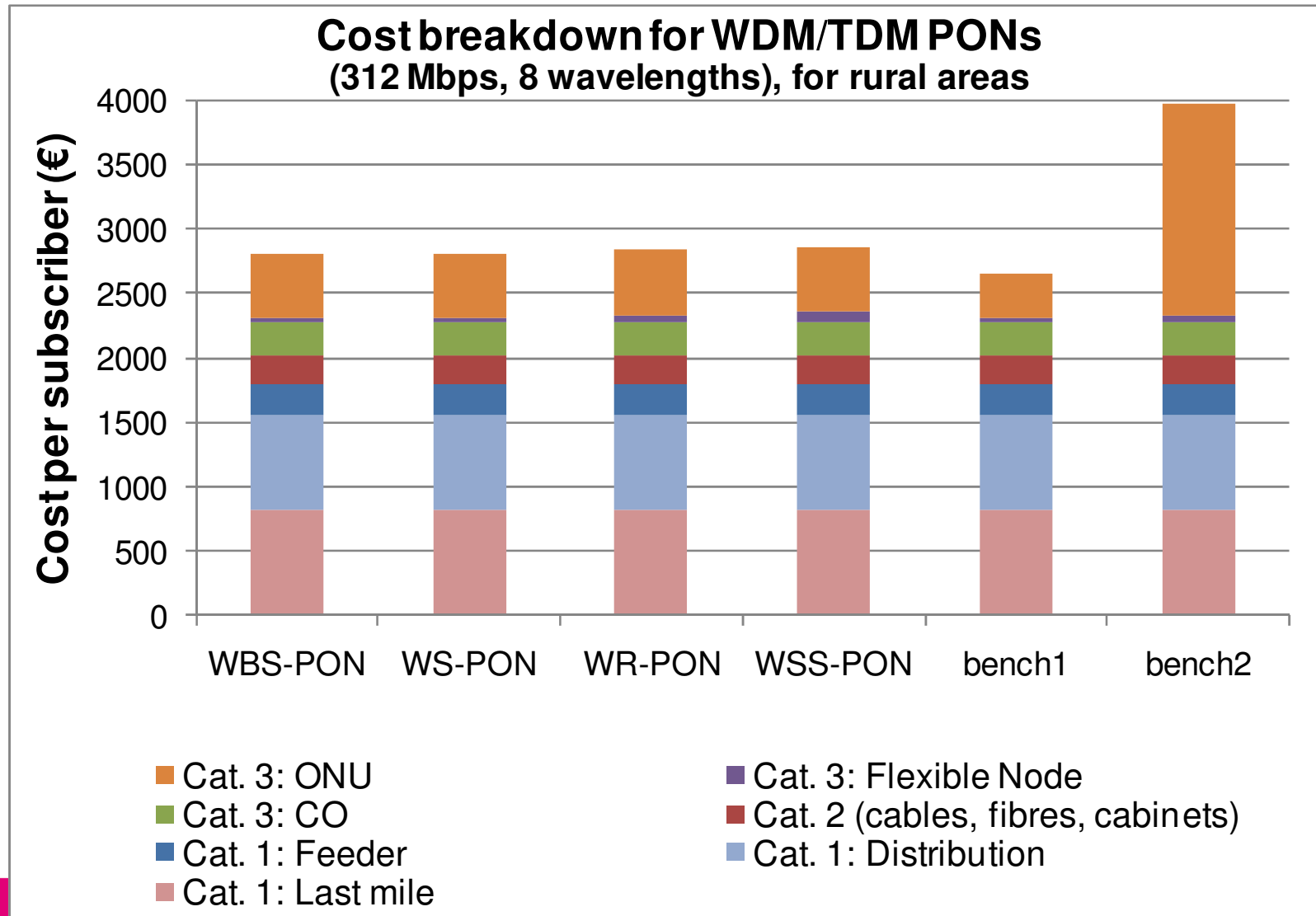

# Outline

- Next-generation optical access (NGOA)
- Hybrid WDM/TDM PON architectures
- Need for flexibility
- MAC protocols
- Techno-economic evaluation
- **Conclusions**

# Conclusion and Future Research Options

- **Hybrid WDM/TDM PON**
  - Promising candidate for the NGOA solution
  - Different variants proposed, with different levels of *flexibility, power budget, security*
- **Switched** hybrids (with SOA or WSS)
  - Can add flexibility without introducing too many active components in the field
- Increased **flexibility at the remote nodes**
  - Limited influence on the total cost
  - Perspectives for advanced hybrid WDM/TDM PONs
- **Research challenges**
  - Design switched hybrids with higher flexibility in a cost-effective way
  - MAC protocol to facilitate DBA and QoS support
  - MAC protocol enabling open business model (open access)



*Thanks for the Attention..  
Any Questions?*



Bart Lannoo  
[bart.lannoo@intec.ugent.be](mailto:bart.lannoo@intec.ugent.be)  
Tel.: (+32) 9 33 14998